

WINGET

OPERATING INSTRUCTIONS & SPARE PARTS LIST

FOUR/40E DIESEL DUMPER (CAPACITY 40 CWT)

**ISSUED OCTOBER 1972, MAY
1974 & JANUARY 1975
REPRINTED JULY 2002**

**WINGET LIMITED
PO BOX 41
EDGEFOLD INDUSTRIAL ESTATE
PLODDER LANE
BOLTON
LANCS
BL4 OLS**

**TEL: ++ 44 (0) 1204 854650
FAX: ++ 44 (0) 1204 854663
service@winget.co.uk
parts@winget.co.uk
www.winget.co.uk**

INTRODUCTION

This Parts & Operators Manual is a re-print of the manual last published in 1975 and contains some amended part numbers.

Health & Safety legislation and working practices applicable to Site Dumpers, both 2 and 4 wheel Drive, Rigid Chassis and Articulated Chassis have changed considerably in the years since this manual was last published and immediately following this Introduction are notes on the Safe Use of Site Dumpers. These notes supersede and replace all previous 'Dumper Safety' notes issued with Winget FOUR/40E Four Wheel Drive Dumpers

Reference is made on a number of pages to 'bolt c/w nut and washer', this no longer the case, fixings such as nuts, bolts, screws and washers should be ordered as individual items. A number of Whitworth and B.S.F fixings are now no longer available, in these cases the nearest metric equivalent size will be supplied.

The contents of this manual although correct at the time of publication, may be subject to alteration by the manufacturers without notice and Winget Limited can accept no responsibility for any errors or omissions contained within the following pages. Nor can we accept any liability whatsoever arising from the use of this manual howsoever caused.

Winget Limited operate a policy of continuous product development. Therefore, some illustrations or text within this publication may differ from your machine.

NOTE

Dumpers with standard earth skips will be C.D.P. (Central Driving Position) from Serial Number 4/40E 659

WINGET LIMITED
PO BOX 41
EDGEFOLD INDUSTRIAL ESTATE
PLODDER LANE
BOLTON
LANCS
BL4 OLS
TEL ++ 44 (0) 1204 854650
FAX ++ 44 (0) 1204 854663
E mail service@winget.co.uk
parts@winget.co.uk
www.winget.co.uk

DUMPER SAFETY

Safety is the responsibility of all persons working with this machine. Think "safety" at all times. Read and remember the contents of this handbook.

MACHINE MODIFICATIONS

WARNING Any modifications to the machine will affect its working parameters and safety factors. Refer to the Manufacturers before fitting any non-standard equipment or parts.



The Manufacturers accept no responsibility for any modifications made after the machine has left the factory, unless previously agreed by the Manufacturers in writing; the Manufacturers will accept no liability for damage to property, personnel or the machine if failure is brought about due to such modifications, or fitment of spurious parts.

TRAINING

WARNING Only trained operators should use this machine.



Operators should hold an appropriate full motor vehicle driving licence and undergo both a safety awareness course and a driver training course for Site dumpers run by the C.ITB or equivalent body leading to the award of a CTA.

It is strongly recommended that operators read the H.S.E. publication "Safe Working with Small Dumpers" which is available from government bookshops (HMSO) or from other bookshops quoting the following number ISBN 011 8836935. Another useful publication is British Standard number BS 6264, "Procedure for Operator Training For Earth Moving Machinery" available from the British Standard Institution.

OPERATION

WARNING *NEVER* use the machine for purposes other than those for which it was designed. This machine was designed to carry loads such as soil, clay, sand, wet concrete, stone or other similar materials. It was not designed to carry loads which may move around in the skip uncontrollably, nor to carry any loads or materials which overhang the skip in any way. If in any doubt as to the suitability of this machine for a particular task, contact your nearest Distributor or the Manufacturer for advice.



ALWAYS be aware of local and national regulations governing the use of the machine.

NEVER commence work with the machine until the "Daily (or every ten hours)" service checks have been made. (See *Service Section for details*)

ALWAYS check wheel nut tightness daily.

NEVER carry passengers.

Where seat belt restraints are fitted as part of Rops/Fops Protection they must be worn. Ensure that the seat and seat belt are securely fixed to the machine. Check that the seat belt is in good condition, free from cuts and frayed edges.

ALWAYS remain in the driving seat whenever the engine is running. Never attempt to operate any controls unless seated.

ALWAYS apply the parking brake before leaving the driver's seat.

DUMPER SAFETY

NEVER dismount with the engine running, and never leave the machine unattended with the key in the starter switch.

When Battery Isolators are fitted they must be activated only when the engine is turned off except in cases of emergency.

Activating a Battery Isolator when the engine is running can result in damage to the electrical components and circuits.

NEVER fill the fuel or hydraulic tanks with the engine running.

ALWAYS drive only on surfaces that are known to be stable.

ALWAYS keep the floor plates and walkways clean.

NEVER drive the machine close to the edge of any excavation. Always use effective wheel stops to prevent the machine running close to the edge. Make sure that the stops are in proportion to the size of the wheels and are set sufficiently far enough back from the edge of any excavation to prevent the weight of the load causing a collapse.

NEVER adjust the tyre pressures in an attempt to improve traction on soft ground or obtain a softer ride on hard ground. Incorrectly adjusted tyres can affect the steering and handling characteristics.

NEVER attempt to free a machine which is 'bogged down' by pushing with the bucket of a backhoe loader, tracked excavator or other similar machine.

NEVER make unnecessary "crash stops" when travelling at speed, especially in forward direction.

NEVER work under an unpropped skip. *If the dumper was supplied with a special Skip Support always ensure that it is used.*

Some articulating dumpers are manufactured with an articulation lock. If your machine has this feature proceed as follows:

ALWAYS fit the articulation lock when working within the articulation point crush zone.

NEVER attempt to lift the machine unless the articulation lock is engaged.

SKIPS AND LOADING

WARNING *NEVER* exceed the rated payload. The weights of all loads above skip water level must be checked.



NEVER remain on the machine when loading the skip with excavators or loaders. Stop the engine, apply the parking brake, dismount, and stand well clear.

ALWAYS ensure that the load is evenly distributed in the skip.

NEVER carry loads or heap materials in such a manner as to affect the forward vision.

ALWAYS take extra care when tipping non free running loads.

NEVER use the skip in a tipped position to bulldoze heaped materials level or to backfill material into excavations.

DUMPER SAFETY

TOWING

WARNING NEVER attempt to start the engine of a dumper by towing or pushing.



Dumpers are not designed as towing vehicles, but loads (including weight of trailer) not exceeding the rated payload of the dumper may be towed on dry level ground in first gear, providing the dumper skip is loaded with half the rated payload to ensure tyre adhesion when braking.

ALWAYS use a purpose made towing pin.

NEVER tow loads up, down or across gradients.

GRADIENTS

WARNING NEVER operate *Four Wheel Drive articulated steer dumpers* on any gradients which exceed 25% (1 in 4), or across gradients which exceed 16% (1 in 6).



NEVER operate *Two Wheel Drive rigid chassis dumpers* on any gradients which exceed 10% (1 in 10), or across gradients which exceed 10% (1 in 10).

ALWAYS remember that slippery or loose surface conditions can adversely affect safe machine operation, including braking, particularly on gradients.

ALWAYS choose routes that avoid steep, slippery or loose gradients.

NEVER coast down gradients. Always negotiate gradients in first gear.

ALWAYS drive forwards up gradients when loaded.

ALWAYS reverse down gradients when loaded.

ALWAYS keep the load facing uphill.

NEVER park on a gradient. If this is unavoidable, ALWAYS chock the wheels.

NEVER attempt to turn on a gradient.

NEVER tow up, down or across a gradient.

NEVER operate high discharge or rotating skips on gradients.

HYDRAULICS

WARNING ALWAYS "Dump" residual pressure from the system before leaving the machine or before carrying out any maintenance or adjustments.



If maintenance work requires the skip to be in the raised position, then it must be raised and supported before dumping the pressure.

Dump pressure by switching off the engine, then moving the hydraulic control lever several times in each direction.

NEVER leave the machine unattended with pressure in the system.

ALWAYS purge hydraulic rams before commencing work. With the engine running operate the hydraulic control to fully extend and retract the rams.

ALWAYS practise the greatest cleanliness in maintaining hydraulic components.

DUMPER SAFETY

SERVICING

WARNING ALWAYS report any defect at once, before an accident or consequential damage can occur.



ALWAYS conform to service schedules except where:

- 1 Warning lights or warning indicators call for immediate attention.
- 2 Adverse conditions necessitate more frequent servicing.

ALWAYS wear correctly fitting protective clothing. Loose or baggy clothing can be extremely dangerous when working on running engines or machinery.

ALWAYS, where possible, work on or close to engines or machinery only when they are stopped. If this is not practical, remember to keep tools, test equipment and all parts of your body well away from the moving parts.

ALWAYS dump pressure from the hydraulic system before carrying out any kind of maintenance or adjustment. (*see Hydraulics Warnings*).

ALWAYS avoid contact with exhaust pipes, exhaust manifolds and silencers when the engine is running; these can be very hot.

ALWAYS work out of doors, or in a well-ventilated area.

NEVER run an engine in an enclosed space. Exhaust fumes in enclosed areas can kill.

ALWAYS disconnect battery cables and remove battery before using an external charger, carrying out welding repairs or to prevent unauthorised usage when unattended or during a repair.

NEVER allow unqualified personnel to attempt to repair, remove or replace any part of the machine, or anyone to remove large or heavy components without adequate lifting tackle.

NEVER attempt to modify or repair Rops Frames or Fops Canopies by welding, drilling or any other means. Attempts to do so will invalidate Rops/Fops Certification.

ALWAYS obtain advice before mixing oils; some are incompatible. If in doubt drain and refill.

NEVER allow oils and fuels to come into regular contact with skin. This can lead to serious skin diseases including, medical evidence suggests, skin cancer. ALWAYS wear protective gloves when handling oils and fuels whether topping up, draining or refilling. ALWAYS wash hands if oils or fuels come into contact with the skin.

Many liquids used in this machine are harmful if taken internally or splashed into the eyes. In the event of accidentally swallowing oils, fuels, anti-freeze, battery acid etc, DO NOT encourage vomiting, seek qualified medical assistance immediately.

ALWAYS dispose of waste oils and fuels into waste oil storage tanks. If storage tanks are not available consult your distributor or local authority for addresses of local designated disposal points. It is illegal to dispose of waste oil into drains or water courses or to bury it.

DUMPER SAFETY

Equipment which includes friction materials will sometimes contain asbestos. When removing friction material dust from components, such as when servicing brakes or clutches, do not blow out with an airline; it could be harmful to inhale the dust. Remove the dust with a vacuum cleaner or wipe clean with a damp rag. Waste should be placed in a sealed container, marked, and disposed of in accordance with local or national regulations.

The accumulated dust found in clutch housings may contain lead/antimony. No food should be eaten at a work place contaminated by this dust. Hands must be washed before eating. Do not blow out dust with an airline.

ALWAYS ensure that the starting handle is clean and in good condition. Keep the engine starting dog, and the part of the starting handle that mates with it, lightly lubricated (*Refer to the Engine Handbook*).

NEVER work under an unpropped skip. ***If the dumper was supplied with a special Skip Support always ensure that it is used.***

Some articulating dumpers are manufactured with an articulation lock. If your machine has this feature, ALWAYS fit the articulation lock when servicing or working on the machine.

PREPARATION FOR USE

BEFORE THE FOUR/40E DUMPER IS PUT INTO SERVICE ALWAYS CHECK THE FOLLOWING POINTS:—

(See Fig.1)

1. **Engine**
Check the oil level on the dipstick (A), topping up if necessary to the full mark. See also 'Recommended Lubricating Oils',
2. **Gearbox**
Check the oil level on the dipstick (B), topping up if necessary to the full mark. See also 'Recommended Lubricating Oils',
3. **Drive Axles and Transfer Case**
Remove level plugs (C) from drive axles and filler/level plug (D) from transfer case and check that oil is up to bottom of level holes. Top up if necessary through filler plug (E) or filler/level plug (D) if necessary. See also 'Recommended Lubricating Oils',
4. **Fuel Tank**
Fill tank (F) with diesel oil until approximately 1" from the top.

NOTE: Never allow fuel to fall to below 2" deep in the bottom of the tank.

5. **Hydraulic Tank**
Fill the hydraulic tank (G). Before removing the cap, clean the surrounding area, to prevent the possible entry of foreign matter. DO NOT MIX OILS. See 'Recommended Lubricating Oils',
6. **Brake System**
Ensure that the brake master cylinder reservoir (H) is full of brake fluid. Top up if necessary to within 1/4" of the top of the reservoir. Use only Girling Crimson Brake Fluid.
7. **Miscellaneous**
Check all wheel nuts for tightness.
Check all nuts and bolts for tightness. Loose nuts and bolts may lead to damage not covered by the Dumper Warranty.

N.B. For further Lubrication information see Fig.6 and corresponding text

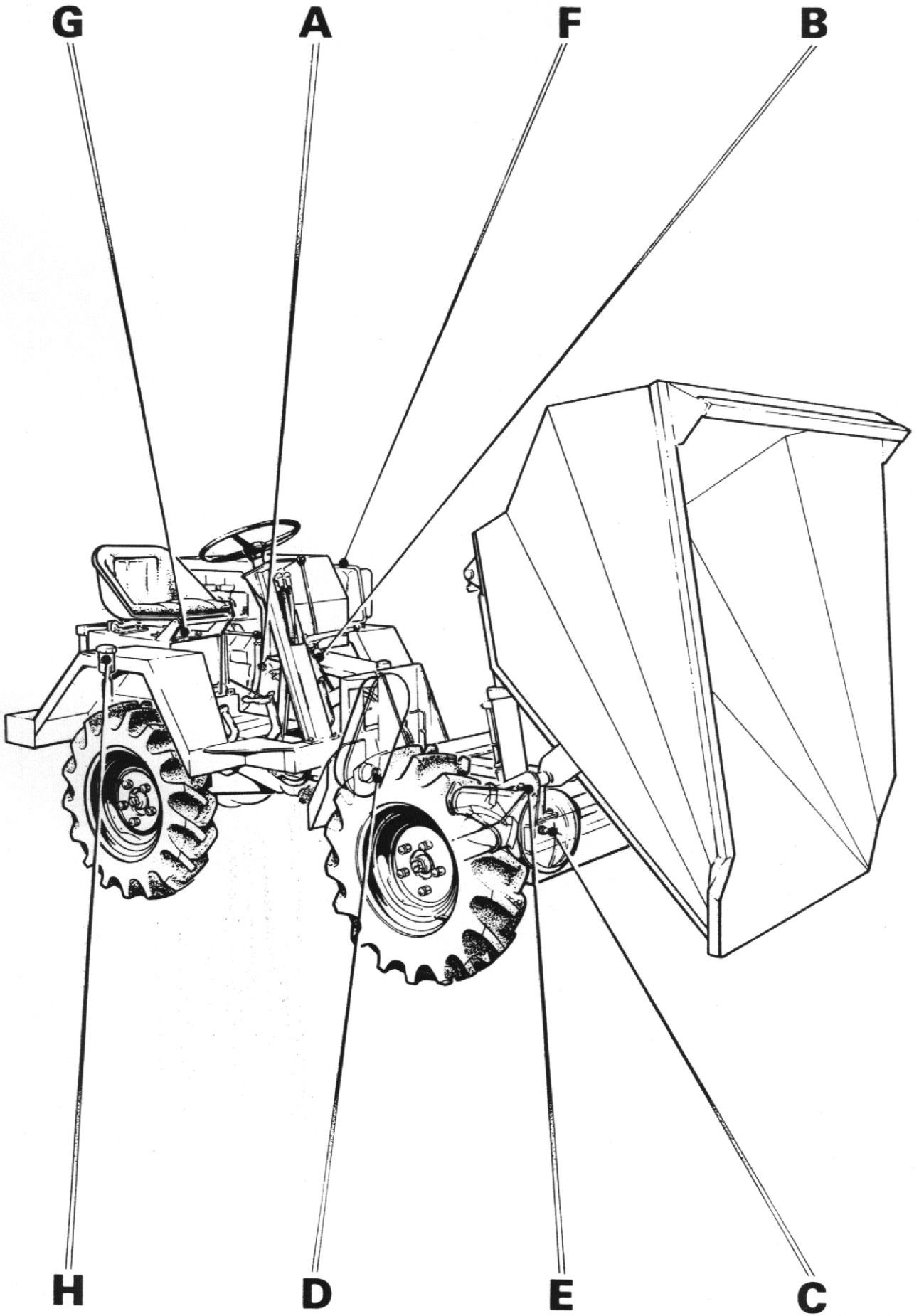

FIG. 1

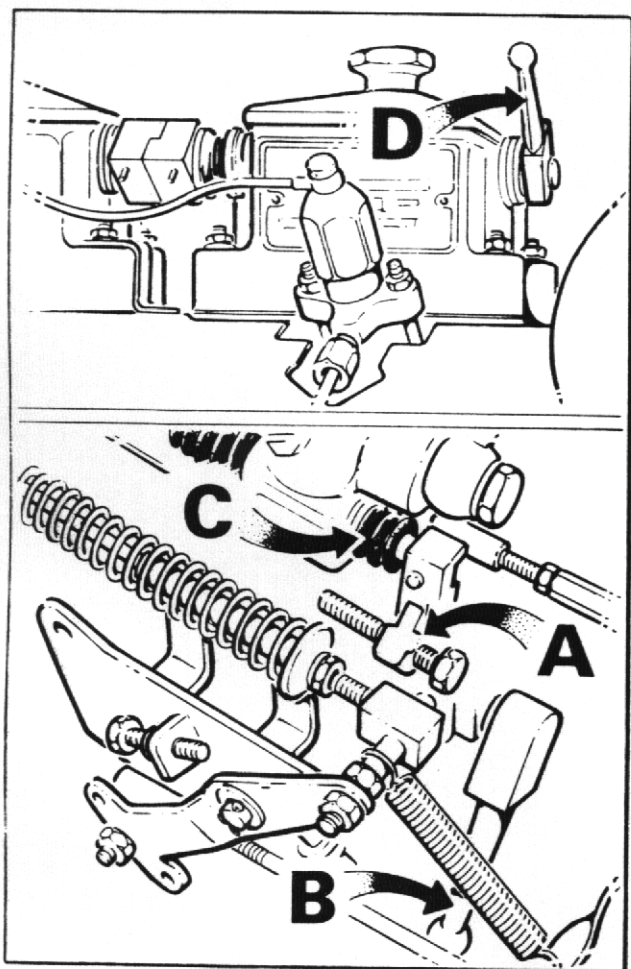

FIG. 2

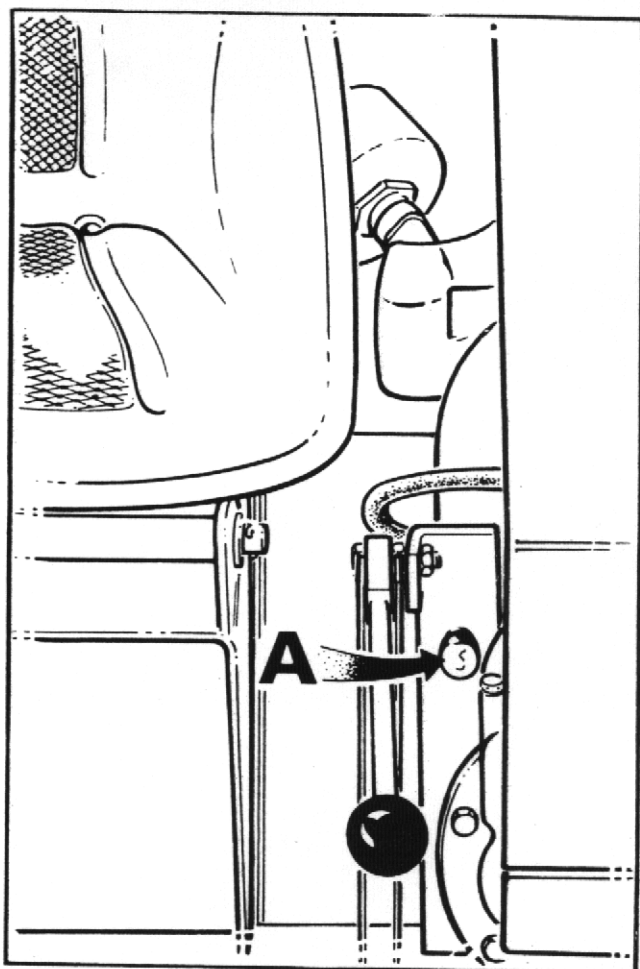

FIG. 3

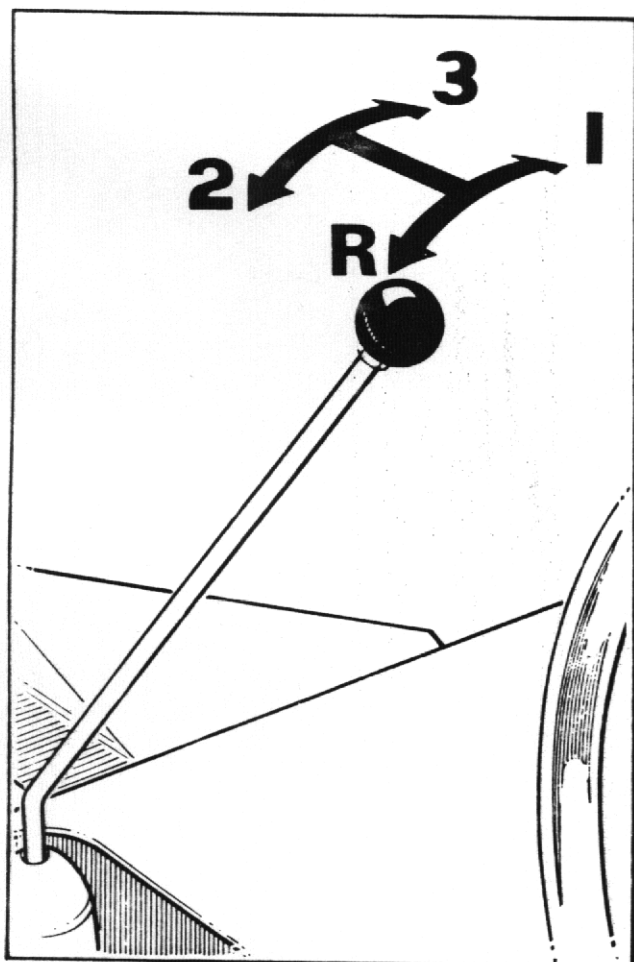

FIG. 4

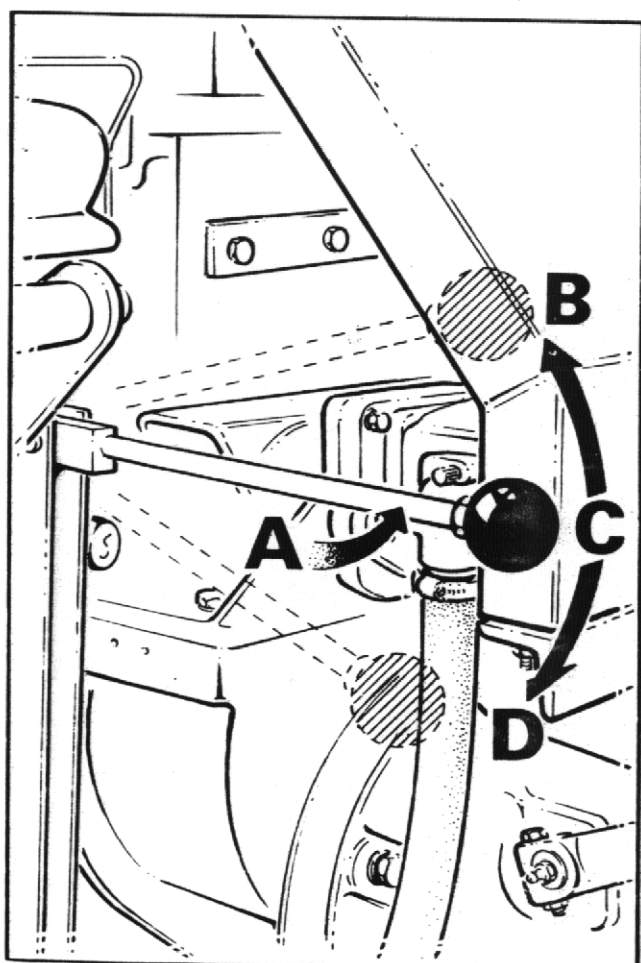

FIG. 5

OPERATION

Starting

(See Fig.2)

1. Lift red-painted overload stop (A) situated on the fuel pump rack above and to the rear of the priming lever (B) and move fuel pump rack (C) into fully-open position.
2. Operate priming lever (B) six times.

NOTE: This is unnecessary if engine is already warm.

3. Lift decompression lever (D), positioned on top of engine and turn engine as fast as possible using starting handle. When engine is turning at a good speed, knock down decompression lever and engine should fire.
4. If engine does not fire, lift decompression lever and slowly crank engine a few times before attempting to start again. Where ambient temperature is 5^oF (-15^oC) or below, a cold start aid should be fitted.

Stopping

(See Fig.3)

Pull out stop control knob (A) and hold in its fully forward position until engine stops. Release stop control knob when engine has ceased to turn.

IMPORTANT:

1. DO NOT stop engine by means of decompression lever, as this will lead to damaged valve seats and cylinder head joint.
2. DO NOT stop engine by closing fuel tap or by allowing fuel tank to run dry, this will allow air into fuel lines and necessitate bleeding and priming system.

Gear Shift Lever

(See Fig. 4)

The Four/40E Dumper is fitted with three forward (1), (2), (3), and one reverse (R) gear. When changing gear, the clutch pedal is used in the normal manner.

Skip Control Lever

(See Fig. 5)

1. Control lever (A) has three positions DUMP (B), HOLD (C), and RETURN (D).
2. Pull lever UP to DUMP (B) to deposit load.
3. Push lever DOWN to RETURN (D) to return skip to carrying position.

NOTE: If lever is released when in DUMP or RETURN position, it will automatically return to HOLD (C) position and motion of skip will cease. In this way, speed at which load is deposited can be finely controlled.

GENERAL MAINTENANCE

Periodic Maintenance

1. DAILY check engine oil level and fill to full mark on dipstick, if necessary.
2. DAILY fill fuel tank, or as often as proves necessary to approximately 1" of top. Never allow there to be a depth of less than 2" of fuel in tank.
3. WEEKLY check oil level in gearbox and fill to full mark on dipstick, if necessary.
4. WEEKLY remove oil level plugs from drive axles and transfer case. Oil level should be to bottom of holes. Top up, if necessary through filler/level plugs on drive axles or through filler/level plug in transfer case.
5. WEEKLY check oil level in hydraulic tank. Always clean the surrounding area before removing cap to prevent possible entry of foreign matter. Fill tank, if necessary, to within 1" of top.
6. WEEKLY check brake fluid level in master cylinder reservoir and top up if necessary, to within 1/4" of top.
7. WEEKLY apply grease to all grease nipples.
8. WEEKLY check all wheel nuts and tighten, if necessary.
9. WEEKLY check tyre pressures 32 lb/sq.in.
10. OCCASIONALLY check all nuts and bolts, and tighten if necessary.

Lubrication (See Fig. 6)

Period	Key	Description	Lubrication	No. of Points
Daily	1	Engine	Engine Oil	1
	2	Fuel Tank	Diesel Fuel	1
Weekly	3	Gearbox	Gearbox Oil	1
	4	Drive Axles	Axle Oil	2
	5	Hydraulic Tank	Hydraulic Fluid	1
	6	Brake Master Cylinder Reservoir	Brake Fluid	1
	7	Footbrake Pedal	Grease Gun	1
	8	Footbrake Master Cylinder Actuating Lever	Grease Gun	1
	9	Footbrake Compensator Lever	Grease Gun	2
	10	Clutch Pedal	Grease Gun	1
	11	Clutch Cross Shaft	Grease Gun	2
	12	Skip Pivot	Grease Gun	2
	13	Handbrake Cable	Grease Gun	1
	14	Chassis Centre Pivot	Grease Gun	2
	15	Front Prop. Shaft U.J.	Grease Gun	1
	16	Transfer Case	Axle Oil	1
	17	Drive Axle Hub Bearings	Grease Gun	4

N.B. FOR RECOMMENDED LUBRICATING OILS SEE CHART

Oil Capacities

Transfer Box 1 pt. (.6 litres)	Drive Axle 8 pts. (4.57 litres)
Gear Box 1½ pts.(.86 litres)	Engine 12 pts. (6.8 litres)

- NOTES: 1. Rear Axle articulation points consist of bearings that require no lubrication.
 2. For full details of the lubrication and maintenance of the engine refer to Manufacturers Manual.

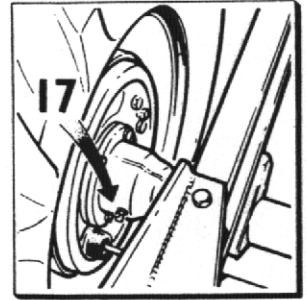
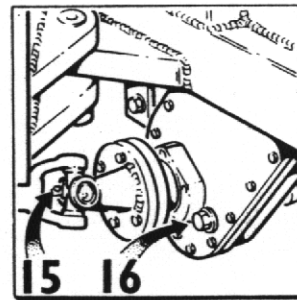
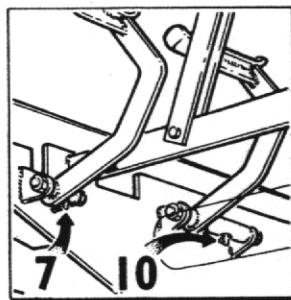
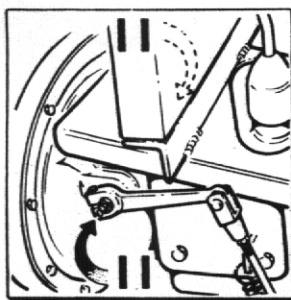
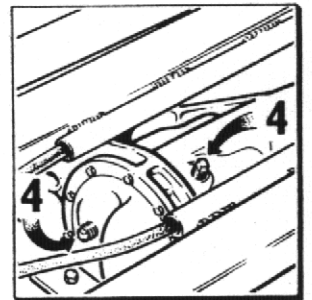
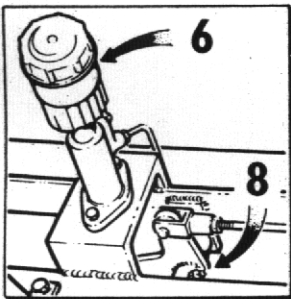
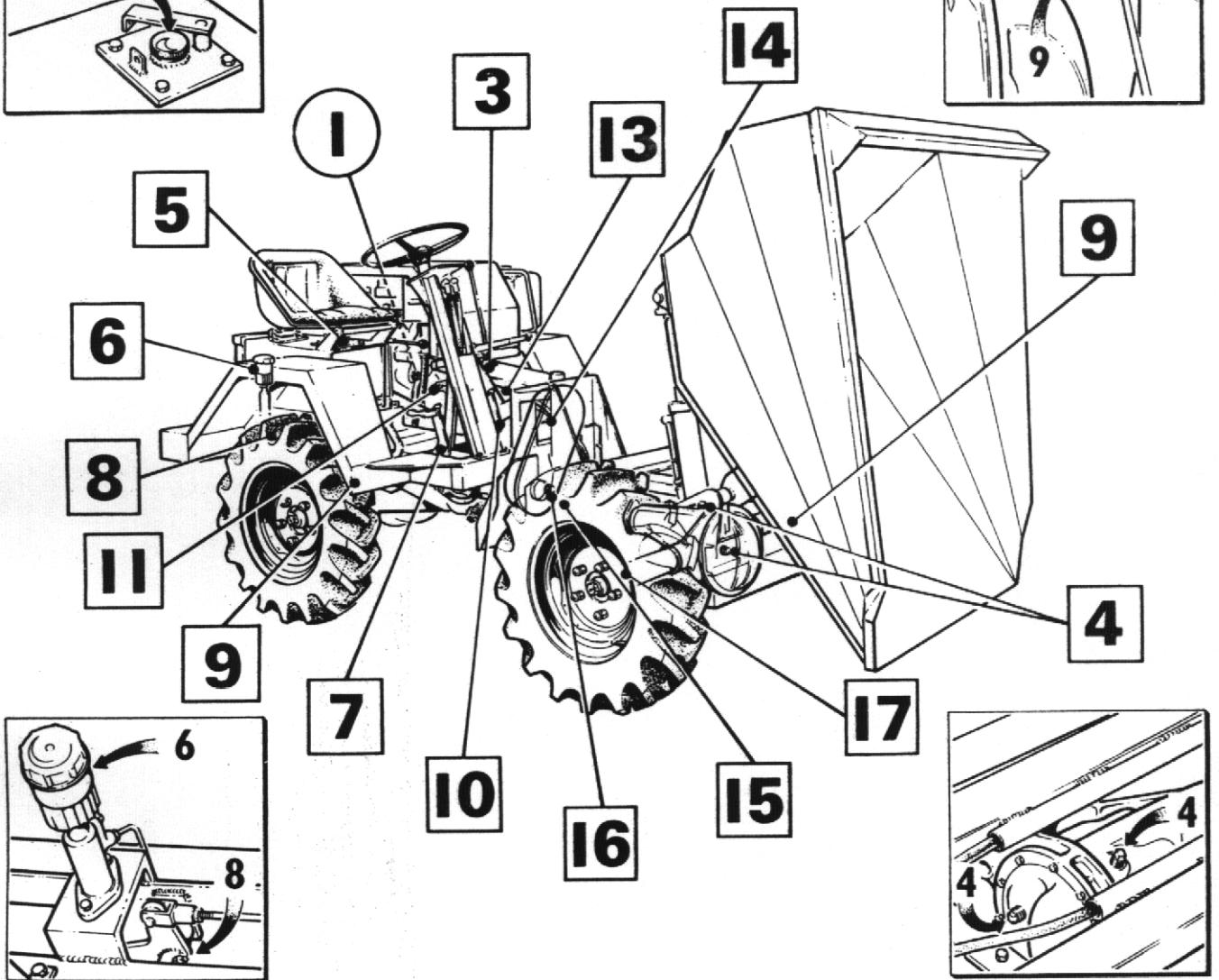
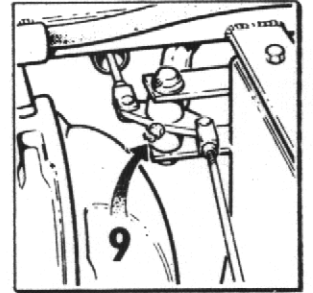
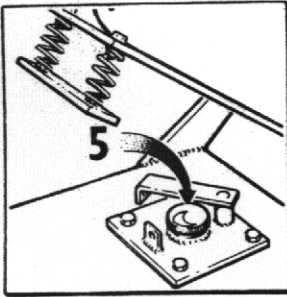
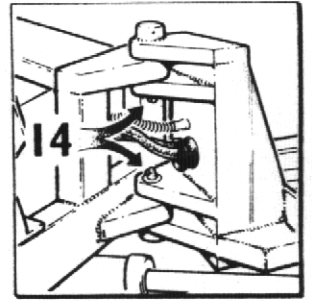
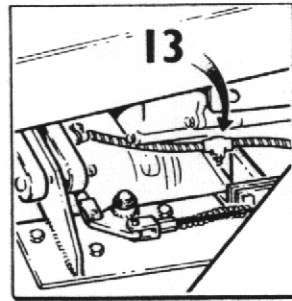
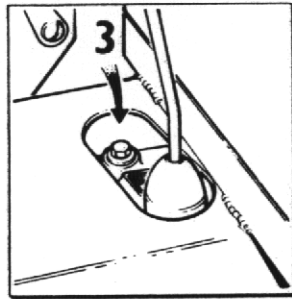
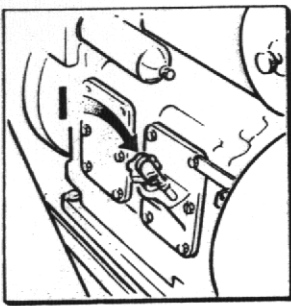

FIG. 6

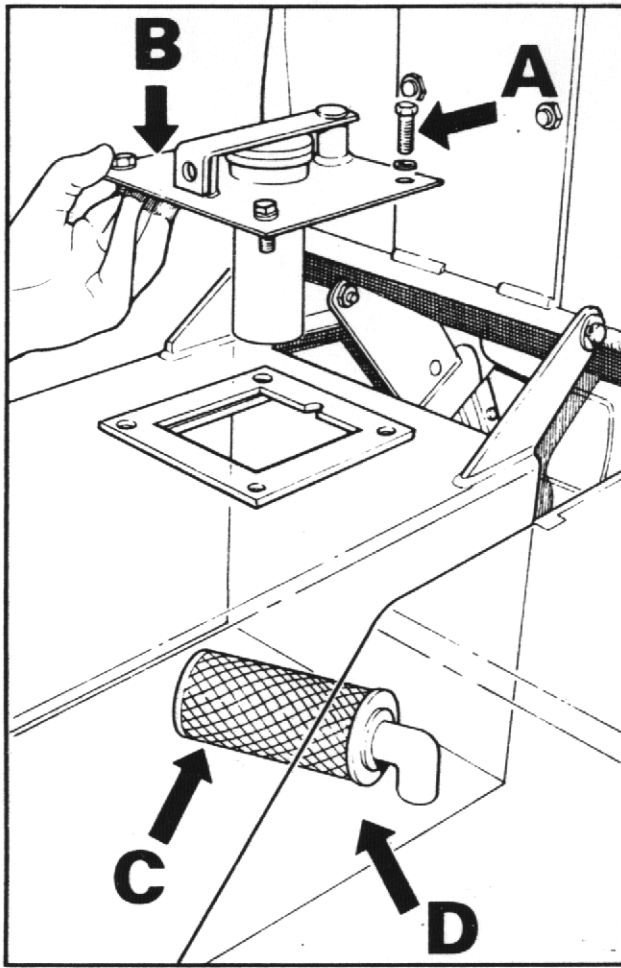

FIG. 7

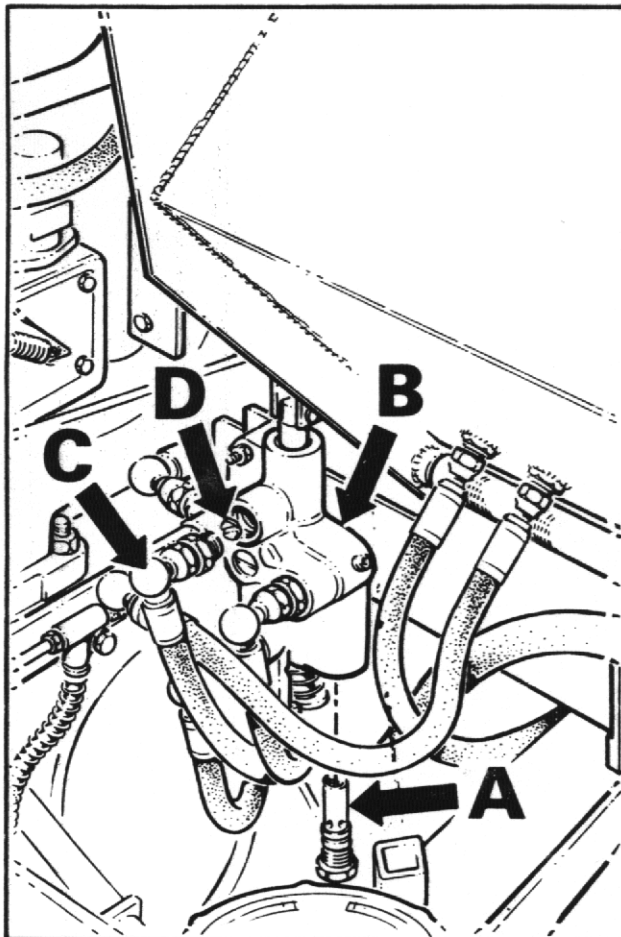

FIG. 8

Main Hydraulic System

The main hydraulic system controls the dumping and return of the skip and also provides the power for the dumper steering. If the system fails to operate or does so extremely slowly, carry out the following procedure until the fault is rectified.

1. Check that hydraulic tank is full of oil.
2. Check that hydraulic filter is not blocked (See Fig.7).
 - a) Remove the four setscrews (A) that secure the filler cap assembly (B) and remove assembly.
 - b) Unscrew suction filter (C) from inside tank (D) and wash in white spirit. Dry with moisture-free compressed air.
 - c) Replace suction filter and filler cap assembly.

NOTE: If suction filter cannot be thoroughly cleaned, fit a new one.

3. Check that hydraulic pressure is correct.
 - a) Fit a 2000 lb/sq.in. gauge into the hydraulic system at the base of the skip ram.
 - b) Operate control lever to dump skip and check that pressure reading on gauge is 1750 lb/sq.in. when ram is fully extended and relief valve is 'blowing'.

NOTE: If correct pressure is not attained –

4. Remove relief valve cartridge (A) (hexagon head) from the bottom of the Control Valve (B) (See Fig.8) and replace with a new one
5. Remove hose adaptor (C) from control valve (See Fig.8), remove hexagonal orifice plate (D) and wash in white spirit. Dry using moisture-free compressed air. DO NOT poke wire etc., into the orifice. Re-fit plate and hose adaptor with slot of orifice plate facing outwards.

IF none of these procedures correct the fault contact your Winget agent. Periodically check the hose between the pump and the tank to ensure it is not deformed. Any deformation in the hose may result in a restricted flow of fluid and damage to the pump.

IMPORTANT:— ON NO ACCOUNT SHOULD THE STEERING VALVE BE DISMANTLED, SHOULD IT REQUIRE ATTENTION REMOVE IT COMPLETE AND RETURN TO THE FACTORY.

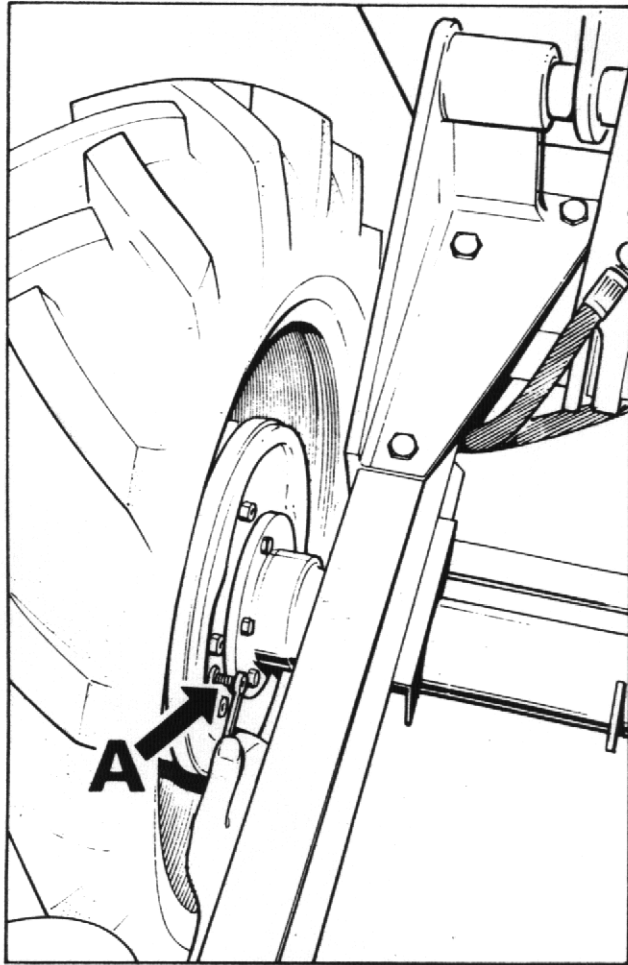

FIG. 9

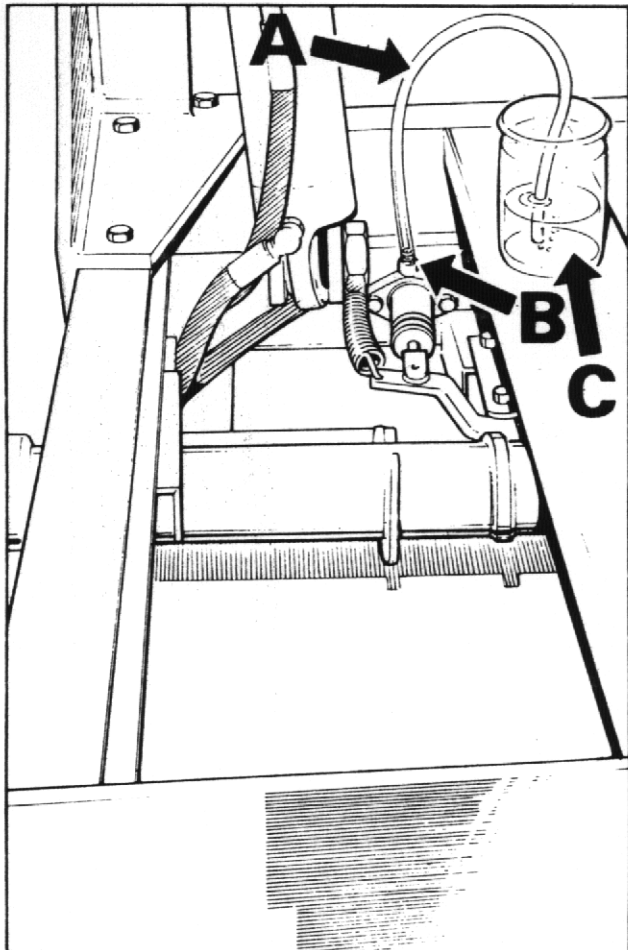

FIG. 10

Brake Adjustment

The brake adjusting screw is located on the rear of the brake back plate (See Fig.9)

- a) Screw the adjuster (A) clockwise until the brakes are fully on.
- b) Then slacken the screw anti-clockwise until the brake shoes are just clear of the drum. This will cause the shoes to be centralised on the drum and ensure the whole brake lining area is used.

Brake System

The brake system is designed to require the minimum amount of maintenance, and, providing the hydraulic fluid in the reservoir is not allowed to fall below the recommended level, no defects should normally occur. Fluid loss must be supplemented by topping up the reservoir with Girling Crimson brake fluid. No other fluid may be used. If air is present in the system it will be indicated by sluggish response of the brakes and spongy action of the brake pedal. This may be due to air being introduced at a loose joint or by the reservoir fluid level being allowed to fall very low. These defects must be remedied immediately and the complete system bled.

To bleed the system proceed as follows:—

1. Check all connections are tight and the bleed screws on the slave cylinders are closed.
2. Fill reservoir with Girling Crimson brake fluid.
3. Attach bleeder tube (A) (See Fig.10) to the bleed screw (B) on the front slave cylinder, immerse the other end of the tube in a small quantity of brake fluid contained in a glass jar (C). Slacken bleed screw and operate brake pedal up and down to its full stroke until fluid pumped into the jar contains no air bubbles. Hold pedal down and close bleed screw. Remove bleeder tube and release pedal.
4. Lock the bleed screw and top up the reservoir to the correct level.
5. Repeat the procedure for the rear slave cylinder.
6. Apply normal working load on brake pedal for two or three minutes and examine system for leaks.

NOTE: DURING THE OPERATION IT IS ESSENTIAL THAT THE RESERVOIR LEVEL IS KEPT TOPPED UP TO PREVENT FURTHER AIR BEING DRAWN INTO THE SYSTEM. ONLY USE NEW FLUID FOR TOPPING UP.

SPECIFICATION FOR MACHINE WITH HYDRAULIC FORWARD TIP SKIP

Key to Fig.11

A.	Overall length	10ft 11 in.	(332cms.)
B.	Overall width	5 ft 5 in	(165 cms.)
C.	Overall height	5 ft 0 in	(152 cms.)
D.	Overall height when tipped	6 ft 0 in	(183 cms.)
E.	Wheelbase	5ft 7¼ in.	(170 cms.)
F.	Skip loading height	4 ft 0 in	(122 cms.)
G.	Skip ground clearance when tipped	6½ in	(17 cms.)
H.	Skip discharge	1ft 5½ in.	(44 cms.)
J.	Reach from tyres	2ft 9½ in.	(85 cms.)
K.	Wheeltrack	4 ft 7 in	(140 cms.)
L.	Prow width	3 ft 0 in	(91 cms.)
M.	Ground clearance	9½ in	(24 cms.)

Skip Capacity

Water level	28 cu. ft	(.80 m ³)
Struck level	35 cu. ft.	(.99 m ³)
Heaped level	42 cu. ft.	(1.19 m ³)
Max. Payload	40 cwt.	(2032 kgs)

Road speeds at 2000 r.p.m.

	mph	kph
1st	3	4½
2nd	6½	10½
3rd	12¼	19½
Rev.	3¾	5

Miscellaneous

Turning circle	23 ft-6in	(716 cms.)
Unladen weight	31 cwt.	(1574 kgs)
Hydraulic relief valve setting	1750 lb/sq in	(123 kg/cm ²)
Hydraulic tank capacity	5 galls	(22.7 litres)
Rear axle articulation	11 in	(28 cms.)

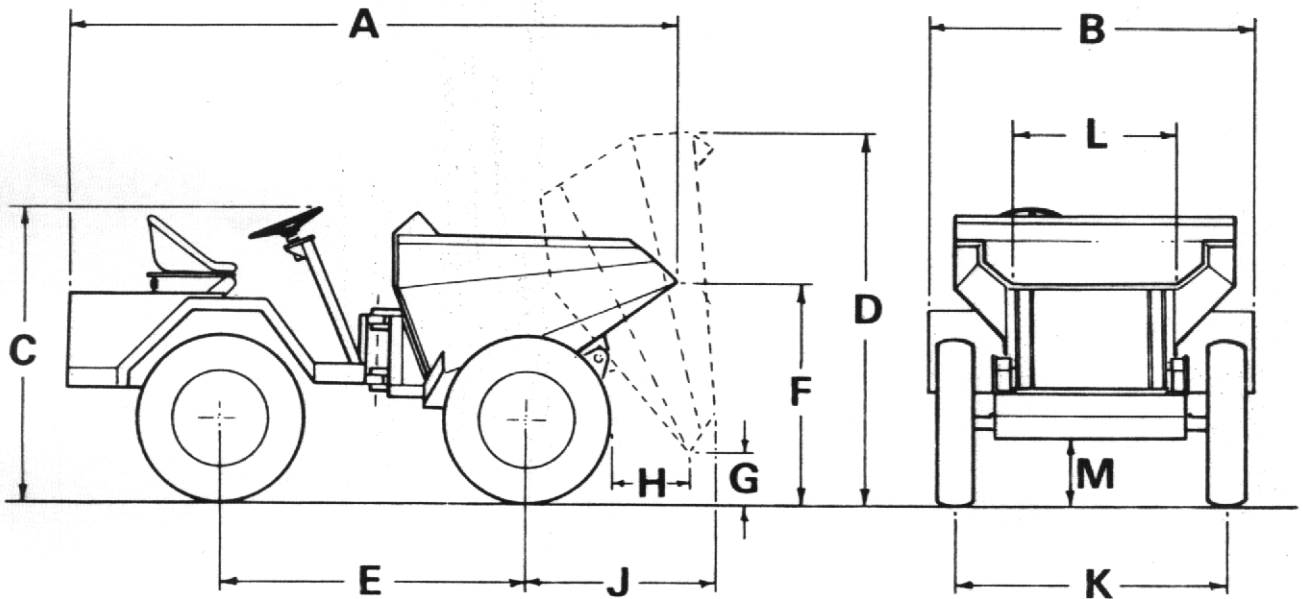

FIG. 11

SPECIFICATION FOR MACHINE WITH HIGH DISCHARGE SKIP

Key to Fig.12

A.	Overall length	10ft 10 in.	(330 cms.)
B.	Overall width	5 ft 5 in	(165 cms.)
C.	Overall height	6ft 3 in.	(191 cms.)
D.	Overall height when tipped	10ft 6 in.	(320 cms.)
E.	Wheelbase	5 ft. 7¼ in.	(170 cms.)
F.	Skip loading height	5ft 8 in.	(173 cms.)
G.	Skip ground clearance when tipped	5ft 2 in.	(158 cms.)
H.	Skip discharge	1ft 10 in.	(56 cms.)
J.	Reach from tyres	3ft 2 in.	(97 cms.)
K.	Wheeltrack	4 ft 7 in	(140 cms.)
L.	Prow width	2 ft 2 in	(66 cms.)
M.	Ground clearance	9½ in	(24 cms.)

Skip Capacity

Water level	34 cu ft
Struck level	—
Heaped level	—
Max. Payload	40 cwt

Road speeds at 2000 r.p.m.

	mph	kph
1st	3	4½
2nd	6½	10½
3rd	12¼	19½
Rev.	3¼	5

Miscellaneous

Turning circle	23 ft 6 in	(716 cms.)
Unladen weight	32 cwt.	(1625 kgs)
Hydraulic relief valve setting	1750 lb/sq in	(123 kgs/cm ²)
Hydraulic tank capacity	5 galls	(22.7 litres)
Rear axle articulation	11 in	(28 cms)

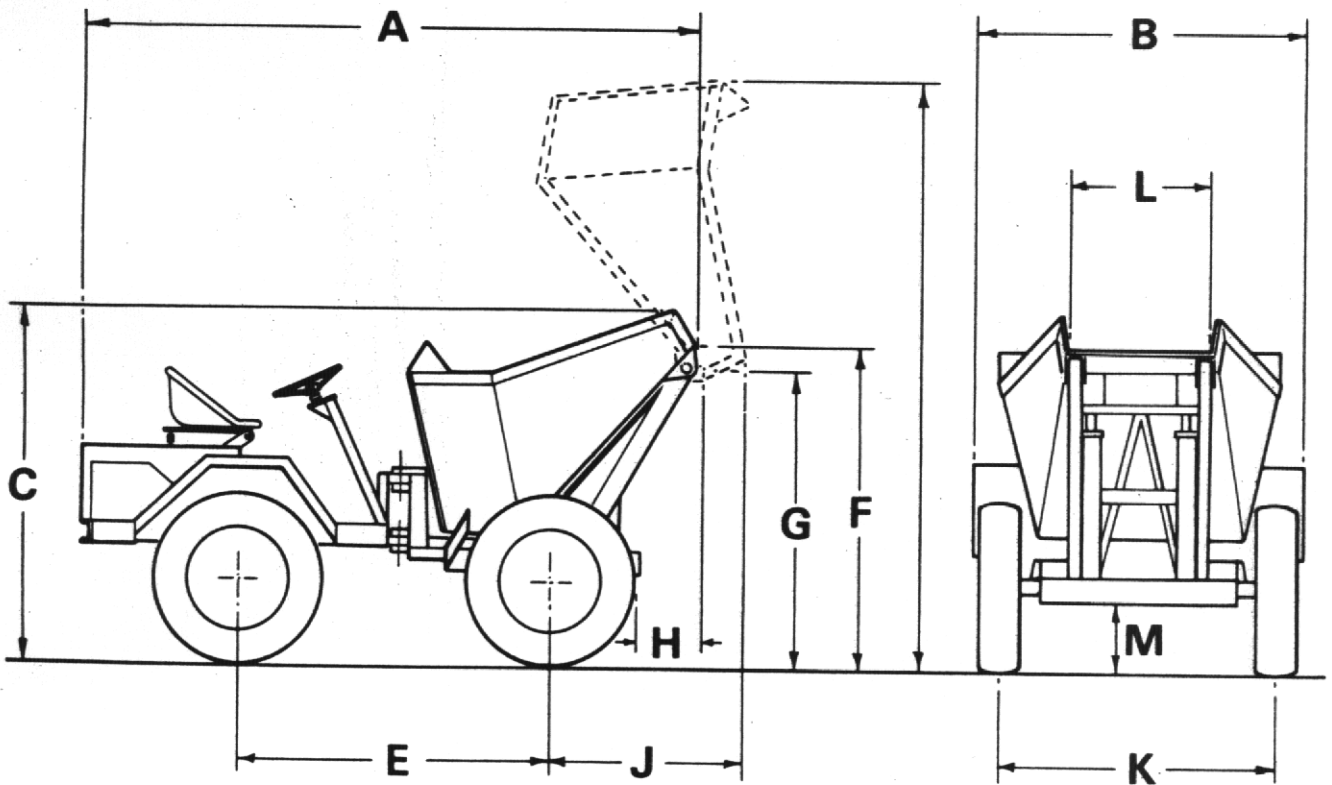

FIG. 12

RECOMMENDED LUBRICATING OILS

Company	Engine Petter	Transfer Box & Drive Axle	Gearbox	Wheel Bearings & Other Grease Points	Hydraulic System
(U.K.) ESSO	Summer Winter Above 90°F 32-90°F (Overseas) Below 32°F	Esso Gear Oil GP 90/140 Esso Gear Oil GP 90/140 Esso Gear Oil GP 90/140 Esso Gear Oil GP 80	Estor HD 30 Essolube HD 30	Beacon 2 Beacon 2	Nuto H 44
(U.K.) CASTROL	Summer Winter Above 90°F 32-90°F (Overseas) Below 32°F	Deusol Gear EP 90 Deusol Gear EP 140 Deusol Gear EP 90 Deusol Gear EP 80	Deusol CRI 30 Deusol CRI 30	Castrol Spheerol APT 2 Castrol Spheerol APT 2	Castrol Hyspin AWS 32
(U.K.) SHELL	Summer Winter Above 90°F 32-90°F (Overseas) Below 32°F	Spirax 90 EP Spirax 140 EP Spirax 90 EP Spirax 80 EP	Rotella S Oil 30 Rotella S Oil 30	Retinax A Retinax A	Tellus Oil 27
(U.K.) BP	Summer Winter Above 90°F 32-90°F (Overseas) Below 32°F	BP Gear Oil SAE 90EP BP Gear Oil SAE 140 EP BP Gear Oil SAE 90 EP BP Gear Oil SAE 80 EP	Energol DD 30 Energol DD 30	Energrease L2 Energrease L2	Energol HL 65
(U.K.) MOBIL	Summer Winter Above 90°F 32-90°F (Overseas) Below 32°F All Temperatures	Mobilube GX 90 Mobilube GX 140 Mobilube GX 90 Mobilube GX 80	Mobil Delvac 1130 Mobil Delvac 1130	Mobilgrease MP Mobilgrease MP	Mobil DTE Oil Light

IN THE UNLIKELY EVENT OF THE ABOVE OILS NOT BEING AVAILABLE
EQUIVALENT OILS SUPPLIED BY A REPUTABLE MANUFACTURER MAY BE USED

SPARE PARTS SECTION

LIST OF CONTENTS

Title	Page No.
CHASSIS	16, 17
MUDWINGS & COVERS	18, 19
HIGH DISCHARGE SKIP & FRAME	20, 21
HYDRAULIC TIP SKIP	22
FLYWHEEL & CLUTCH ASSEMBLY	23
GEARBOX	24-27
TRANSFER BOX & PROP SHAFTS	28, 29
DRIVE AXLE	30-33
DRIVE WHEEL	34
HANDBRAKE UNIT	35
DRUM BRAKE ASSEMBLY	36, 37
BRAKE PIPES & CONNECTIONS	38, 39
BRAKE MASTER CYLINDER ASSEMBLY	40
BRAKE SLAVE CYLINDER ASSEMBLY	41
HANDBRAKE, VALVE CONTROL LEVER & ENGINE STOP CONTROL	42, 43
PEDALS & CONTROLS	44, 45
HYDRAULIC PIPES & FITTINGS	46, 47
HYDRAULIC PUMP & DRIVE	48
HYDRAULIC RAM	49
HYDRAULIC CONTROL VALVE	50, 51
HIGH DISCHARGE HYDRAULIC RAM	52
AIR CLEANER	53

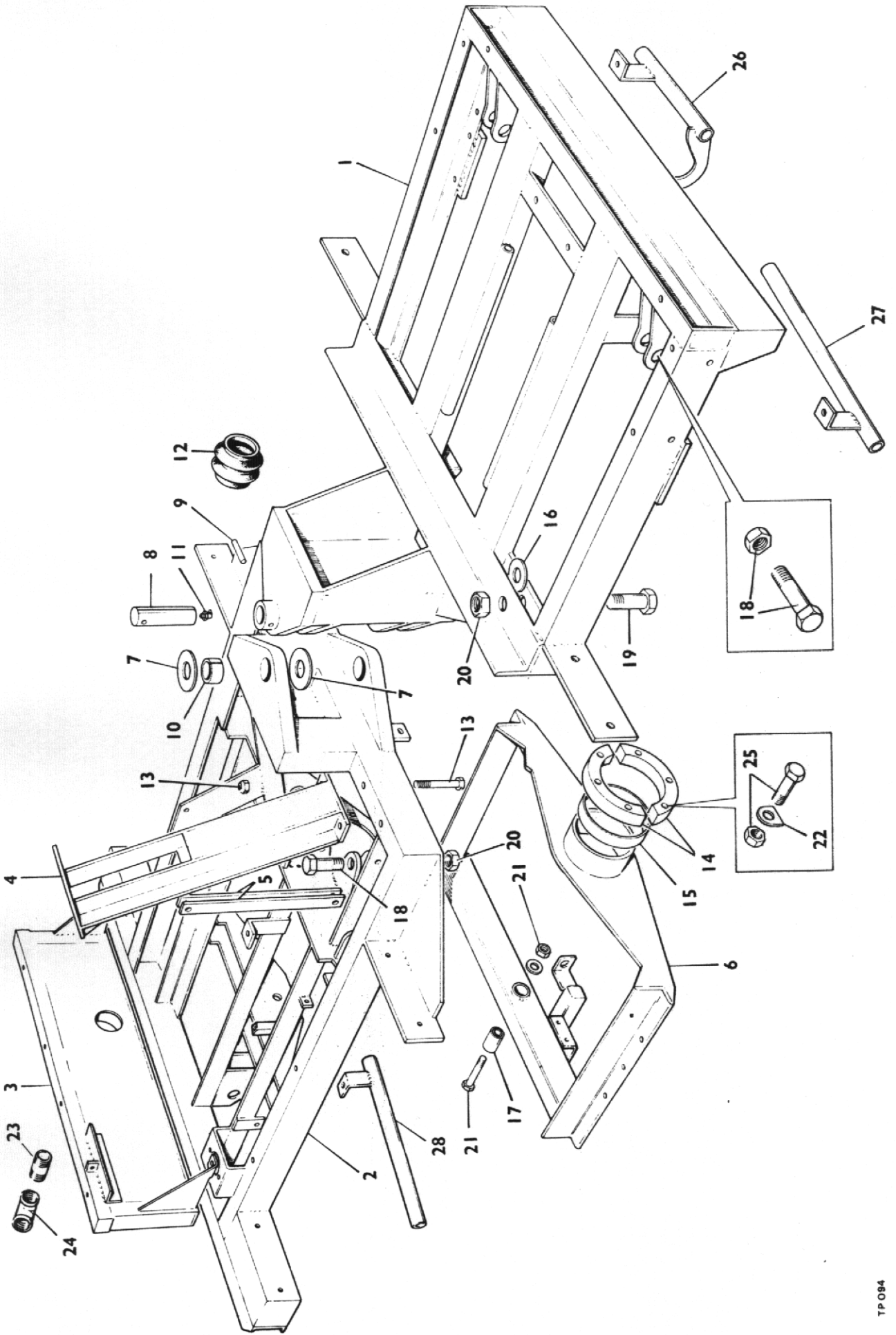

CHASSIS

Item No.	Part No.	Description	Qty.
1	BSE 133	Front chassis Fwd.Hyd. Tip	1
2	BSE 132	Rear chassis (Petter)	1
	BSE 118	Rear chassis (Lister)	1
3	BSE 110	Rear frame (Petter).	1
	BSE 119	Rear frame (Lister).	1
4	4-35-248	Steering Column	1
5	4-35-333	Steering Column Brace	2
6	BSE 101	Articulating Axle Carrier	1
7	4-35-29C	Thrustwasher—Centre Pivot	4
8	4-35-29	Centre Pivot Pin	2
9	4-35-29A	Tension Pin 5/16in Dia x 2½ in Long	2
10	4-35-29B	Centre Pivot Pin Bush	2
11	T 90	Grease Nipple	2
12	ASE 139	Convuluted Hose	1
13		Bolt ½" BSF x 5" long & locknut	2
14	4-35-27	Axle Bearing Carrier	1
15	4-35-26	Axle Carrier Bearing	1
16	F4-45-50	Spacer	1
17	E 2245	Pivot Bush	1
18	4-35-110 A	Bolt—Steering Ram & skip ram (See page 22)	5
19	F4-45-57	Bolt—Steering Ram	1
20	4-35-110B	Nut	2
21		Nut & Bolt 7/8 in BSF x 4 in long	1
22	4-35-145	Axle Bearing Carrier Tab Washer	4
23	4-35-28B	Pipe 1½ in B.S.P.	1
24	ASE 135	Elbow 1½ in B.S.P. F & F x 45°	1
25		Bolt ½ in BSF x 2½ in Long & Nut	6
26	ASE 134 LH	Front LH & Rear R.H. Brake Rod Guard	2
27	ASE 134 RH	Front RH Brake Rod Guard	1
28	BSE 105	Rear LH Brake Rod Guard	1

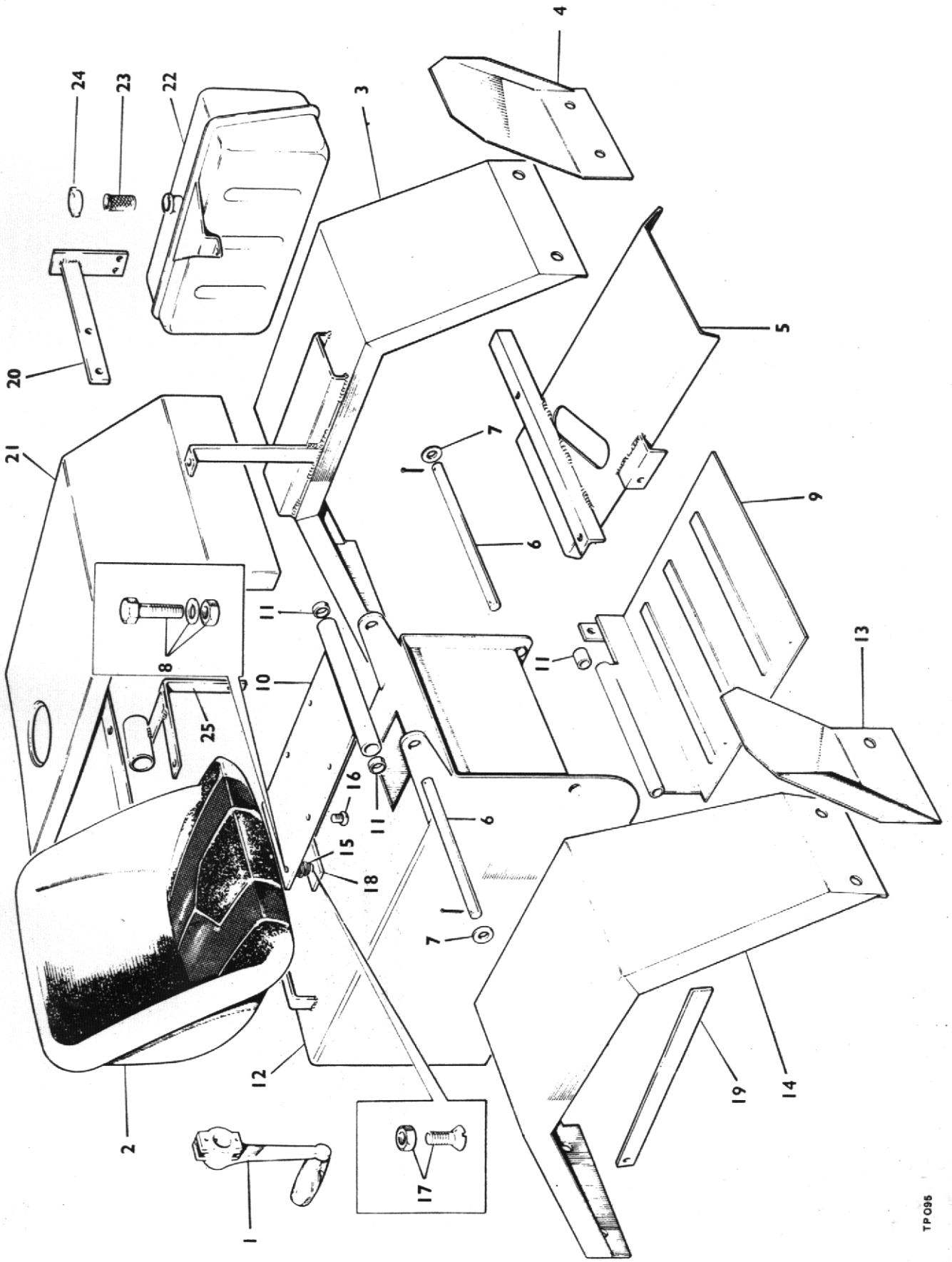

MUDWINGS & COVERS

Item No.	Part No.	Description	Qty.
1	C 188	Starting Handle	1
2	4-35-301	Seat	1
3	BSE 111	Mudwing LH	1
4	2ST 78	Mudflap LH	1
5	BSE 121	Gearbox Cover	1
6	4-35-307	Rod-Seat & Tank	2
7		Flat Washer 1/2in Dia	4
8		Nut & Bolt 3/8in B.S.F. x 1 in Long & Washer	2
9	ASE 116	Footplate (Petter)	1
	BSE 124	Footplate (Lister)	1
10	4-35-296-12	Seat Frame	1
11	WB0808	Bush	4
12	BSE 108	Hydraulic Tank (See pages 46, 47)	1
13	2ST 77	Mudflap RH	1
14	ASE 114	Mudwing RH	1
15	5ST 99	Spring	2
16		Seat Bolts 8 MM x 20 MM Long	4
17		Spring Bolts CSK. Bolt 3/8 in BSF x 1 in Long	2
18	ASE 131	Seat Spring Plate	1
19	BSE 103	Hydraulic Tank Support	1
20	BSE 104	Fuel Filter Support Bracket	1
21	BSE 130	Engine cover (Petter)	1
	BSE 120	Engine cover (Lister)	1
* 22	BAE 7E	Fuel Tank	1
* 23	JE13	Strainer	1
* 24	CE12	Cap	1
25	4-35-241	Air cleaner Adaptor	1

Items 22, 23, and 24. obtainable from Petter agents only.

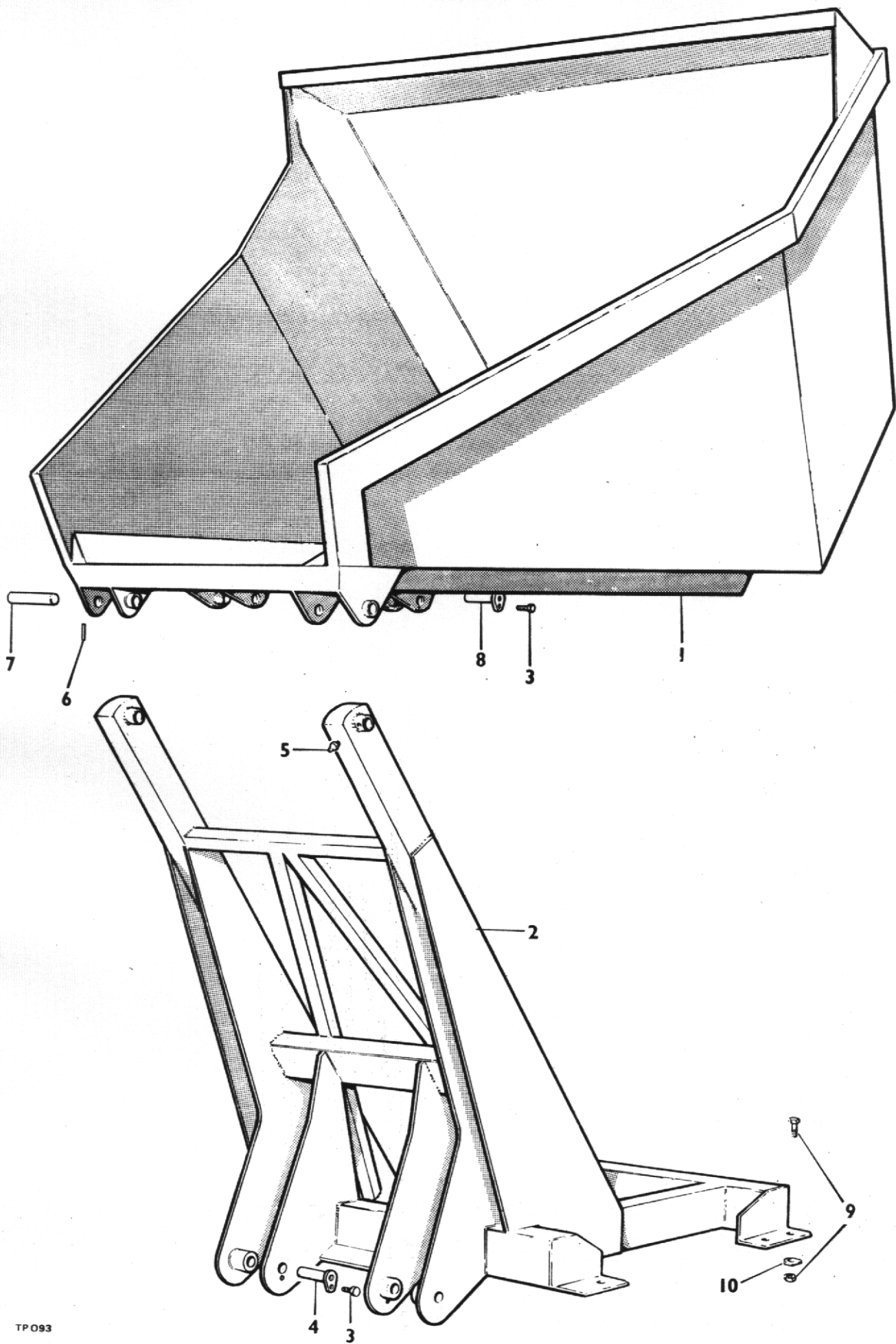

HIGH DISCHARGE SKIP & FRAME

Item No.	Part No.	Description	Qty.
1	4-35-210	Skip	1
2	BSE 146	Frame	1
3		Bolt 5/16" UNF x 3/4" long	4
4	4-35-226	Lower Ram Pin	2
5	5ST 100	Grease Nipple	2
6	4-35-29A	Tension Pin 5/16" dia. x 2 1/4" long	2
7	5ST 84	Skip Pivot Pin	2
8	4-35-178	Ram Pin	2
9		Bolt 1/2 in BSF x 1 1/2 in long & nut	6
10		Taper washer 1/2 in dia	6

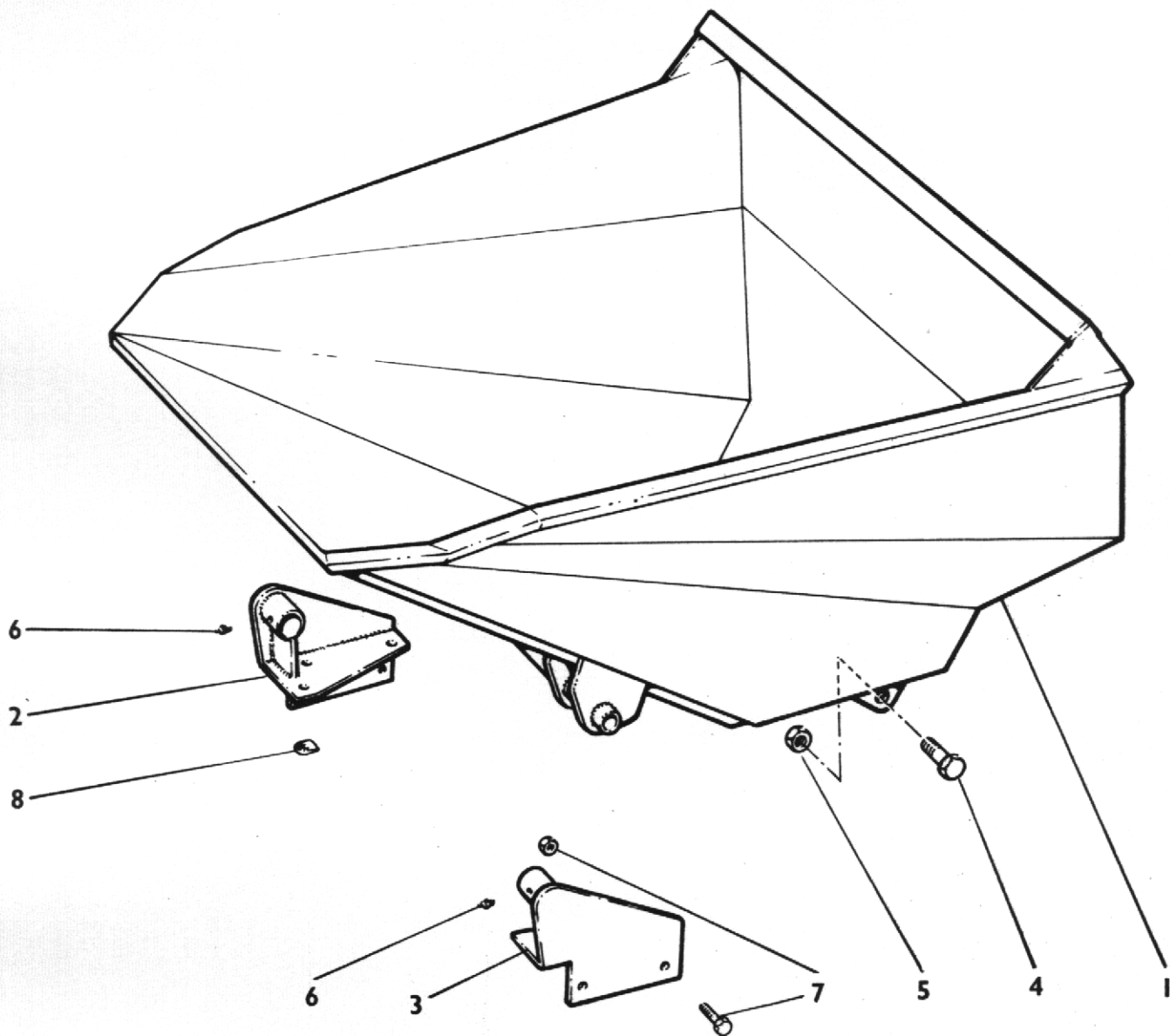

HYDRAULIC TIP SKIP

Item No.	Part No.	Description	Qty.
1	BSE 113	Skip	1
2	ASE 108	Skip Mounting bracket R.H.	1
3	ASE 107	Skip Mounting bracket L.H.	1
4	4-35-110A	Bolt	4
5	4-35-110B	Nut	4
6	5ST 100	Grease Nipple	2
7		Bolt ½ in BSF x 1½ in Long & Nut	10
8		Taper washer	6

FLYWHEEL AND CLUTCH ASSEMBLY

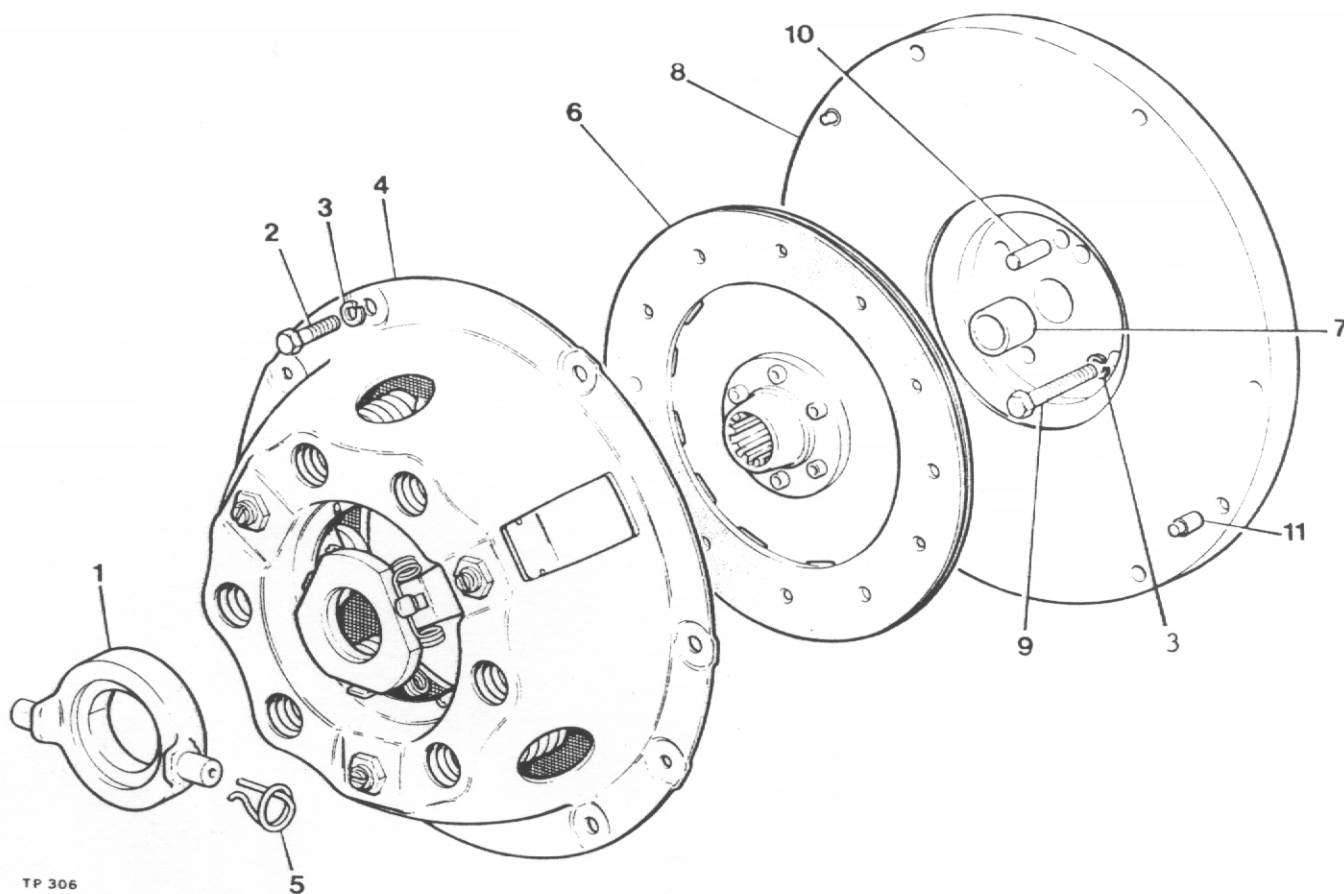

TP 306

Item No.	Part No.	Description	Qty.
1	10579A01	Clutch Release Bearing	1
2	28S02D	Screw Set	6
3	41S04	Washer Spring	10
4	10597A01	Cover Assembly	1
5	10579A101	Retainer Spring	2
6	10598A02	Drive Plate	1
7	10580A0101	Bush	1
8	10580A02	Flywheel Assembly (comprises of items 7, 8, & 11)	1
9	1S02C	Bolt, Petter PH Engine (drill for locking wire)	4
9A	6S02B	Bolt, Lister Engine (drill for locking wire)	4
10	C321	Dowel	1
11	10580A0102	Dowel	2
	10948A02	Clutch Kit (comprises of items 1, 4, 5 & 6)	1

It is recommended that instead of drilling the head of the bolts (item 9) for locking wire that one of each of tabwashers part no's 10531A02 and 10531A03 are used to prevent the bolts working loose.

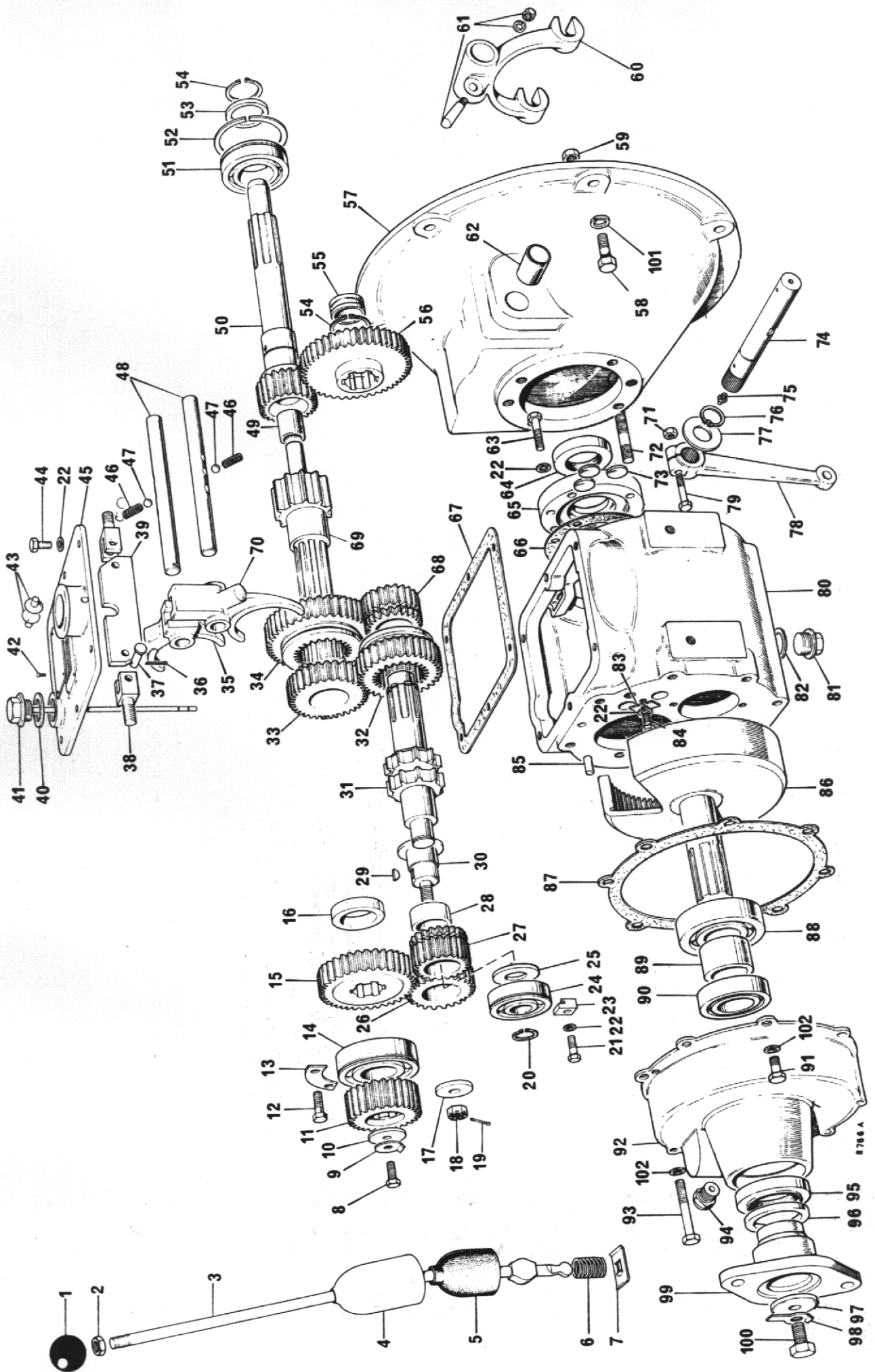

GEARBOX 40M-42-583 INV.-676 (PETTER)

GEARBOX 40M-43-583 INV.-676 (LISTER)

Item No.	Part No.	Description	Qty.
1	40M/133	Knob, Gear Lever	1
2	UN 512	Locknut, Gear Lever	1
3	40M/676	Gear Lever	1
4	40M/377	Cap, Gear Lever	1
5	40M/129	Cover, Gear Lever	1
6	40M/367	Spring, Gear Lever	1
7	40M/245	Retaining Plate, Gear Lever	1
8	USF 53	Screw, Mainshaft	1
9	40M/179	Lockwasher - Tab	1
10	40M/178	Washer, Reduction Pinion	1
11	40M125	Reduction Pinion (Petter)	1
	40M123	Reduction Pinion (Lister)	1
12	USF 11	Screw, Bearing Retainer	2
13	40M/378	Bearing Retainer, Small	1
14	CM/2052	Bearing, Mainshaft Rear	1
15	40M/110	Output Gear	1
16	40M/128	Spacer, Output Gear	1
17	40M/155	Washer, Reverse Pinion Shaft	1
18	UN 507	Nut, Reverse Spindle	1
19	CP/1004	Split Pin	1
20	40M/148	Circlip	1
21	USF/31	Screw	2
22	W104	Spring Washer	16
23	40M/299	Clip, Layshaft Bearing	2
24	40M/146	Layshaft bearing	2
25	40M/130	Bearing Spacer	1
26	40M/111	Reverse Pinion	1
27	40M/114	Reverse Speed Gear	2
28	40M/161	Bush, Reverse Pinion	1
29	40M/222	Key, Reverse Pinion Shaft	1
30	40M/119	Shaft, Reverse Pinion	1
31	40M/118	Layshaft	1
32	40M/116	2nd Speed Sliding Gear	1
33	40M/113	Second Speed Gear	1
34	40M/115	1st Speed Gear	1
35	40M/502	Selector Fork, 2nd & 3rd	1
36	40M/244	Split Pin, Interlock	2
37	40M/232	Clevis Pin, Interlock	2
38	40M/231	Stud, Interlock	2
39	40M/505	Interlock Plate	1
40	CP/1068	Seal, Dipstick	1
41	40M/153	Dipstick	1
42	CP/1003	Drive Screw	4
43	40M/254	Pad, Gear Lever	2
44	USF 21	Screw, Top Cover	6
45	40M/220	Top Cover	1
46	CM/2103	Detent Spring	2
47	CM/1077	Detent Ball	2
48	40M/135	Selector Shaft	2
49	40M/513	Bearing, Primary Shaft	1
50	40M/117	Primary Shaft	1
51	40M/143	Input Bearing	1
52	40M/252	Snap Ring	1
53	40M/174	Bearing Spacer	1
54	CM/2053	Circlip	2
55	40M/162	Bush, Layshaft	1
56	40M/360	1st Reduction Gear	1
57	40M/392	Clutch Housing	1

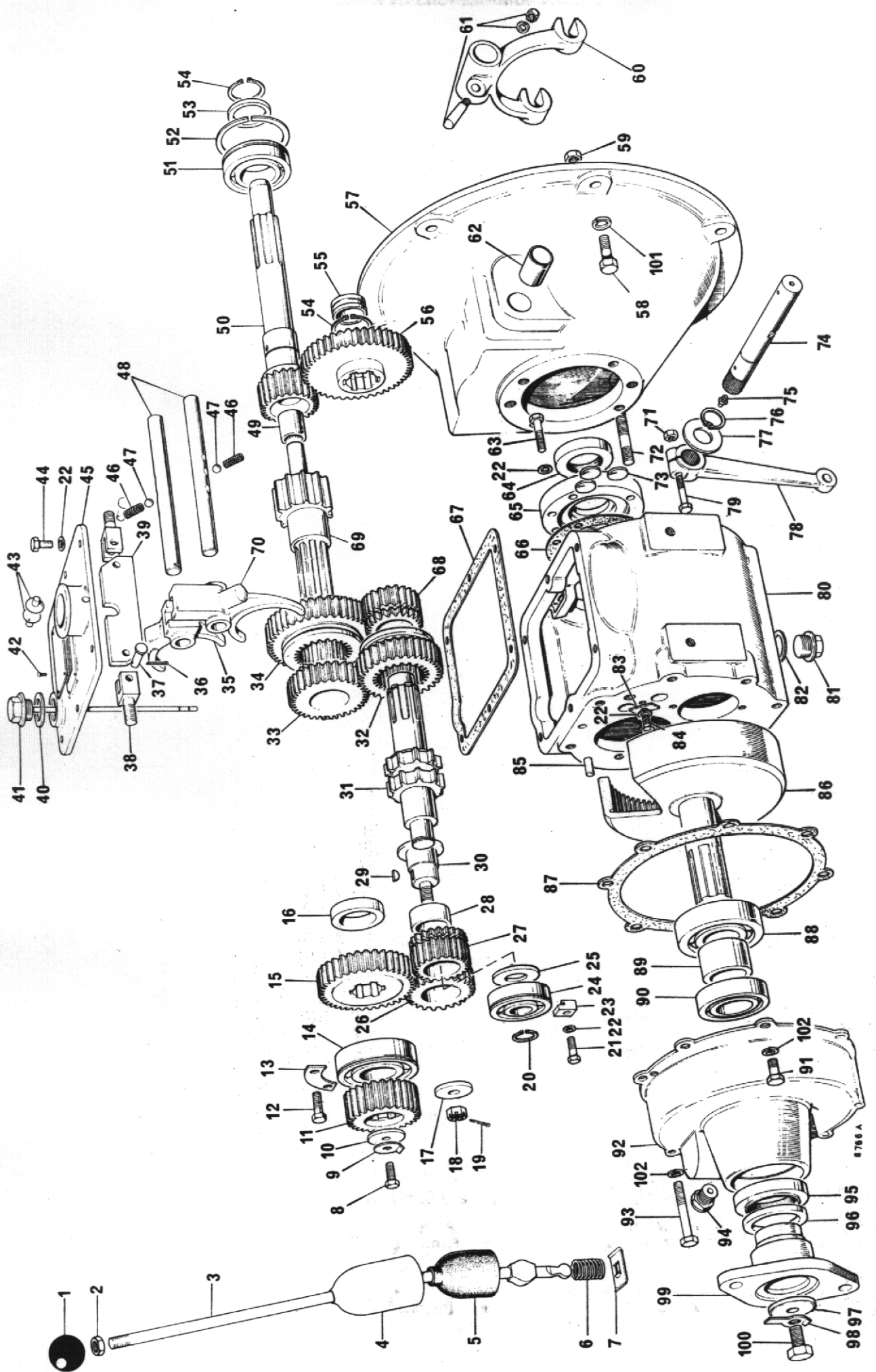

GEARBOX 40M-42-583 INV.-676 (Continued)

Item No.	Part No.	Description	Qty.
58		Bolt Clutch Housing 3/8" BSF x 1" Long - Petter .	6
59	UNL 106	Nut	6
60	CM/2083	Clutch Release Fork	1
61	CM/2084 S/A	Cotter, Nut and Washer S/A	1
62	CM/2179	Bush, Cross Shaft	2
63	UBF 71	Bolt, Front Cover	4
64	40M/150	Oil Seal, Input	1
65	40M/126	Front Cover	1
66	40M/172	Joint, Front Cover	1
67	40M/169	Joint, Top Cover	1
68	40M/114	Reverse Speed Gear	2
69	40M/515	Mainshaft	1
70	40M/501	Selector Fork, 1st. and Reverse	1
71	UN501	Nut, Clutch Lever	1
72	40M/177	Stud, Clutch Housing	6
73	CM/2113	Sealing Disc, Selector Shaft	3
74	40M/394	Clutch Cross Shaft	1
75	CP/1069	Grease Nipple	2
76	CP/1006	Circlip	1
77	40M/398	Washer, Cross Shaft	1
78	CM/2090	Clutch Release Lever	1
79	UBF 91	Bolt, clutch lever	1
80	40M/101/M	Casing	1
81	CP/1002	Drain Plug	1
82	CP/1068	Seal, Drain Plug	1
83	40M/136	Selector Locking Strip	1
84	USF 21	Setscrew	2
85	40M/656	Dowel	2
86	40M/120	Internal Gear	1
87	40M/654	Joint, Reduction Housing	1
88	CM/2068	Bearing, Internal Gear Front	1
89	40M/138	Spacer	1
90	40M/149	Bearing, Internal Gear Rear	1
91	USF 32	Hex. Head Screw	5
92	40M/655	Reduction Housing	1
93	UBF/142	Hex. Head Bolt	3
94	CM/2106	Breather	1
95	40M/167	Oil Seal, Rear	1
96	CM/2537	Dust Shield	1
97	CM/2123	Washer, Coupling	1
98	CM/2050	Lock Washer	1
99	40M/583	Coupling	1
100	USF 55	Screw, Coupling	1
101		Spring Washer 3/8"	6
102		Spring Washer 5/16"	8

1
- ASSY.

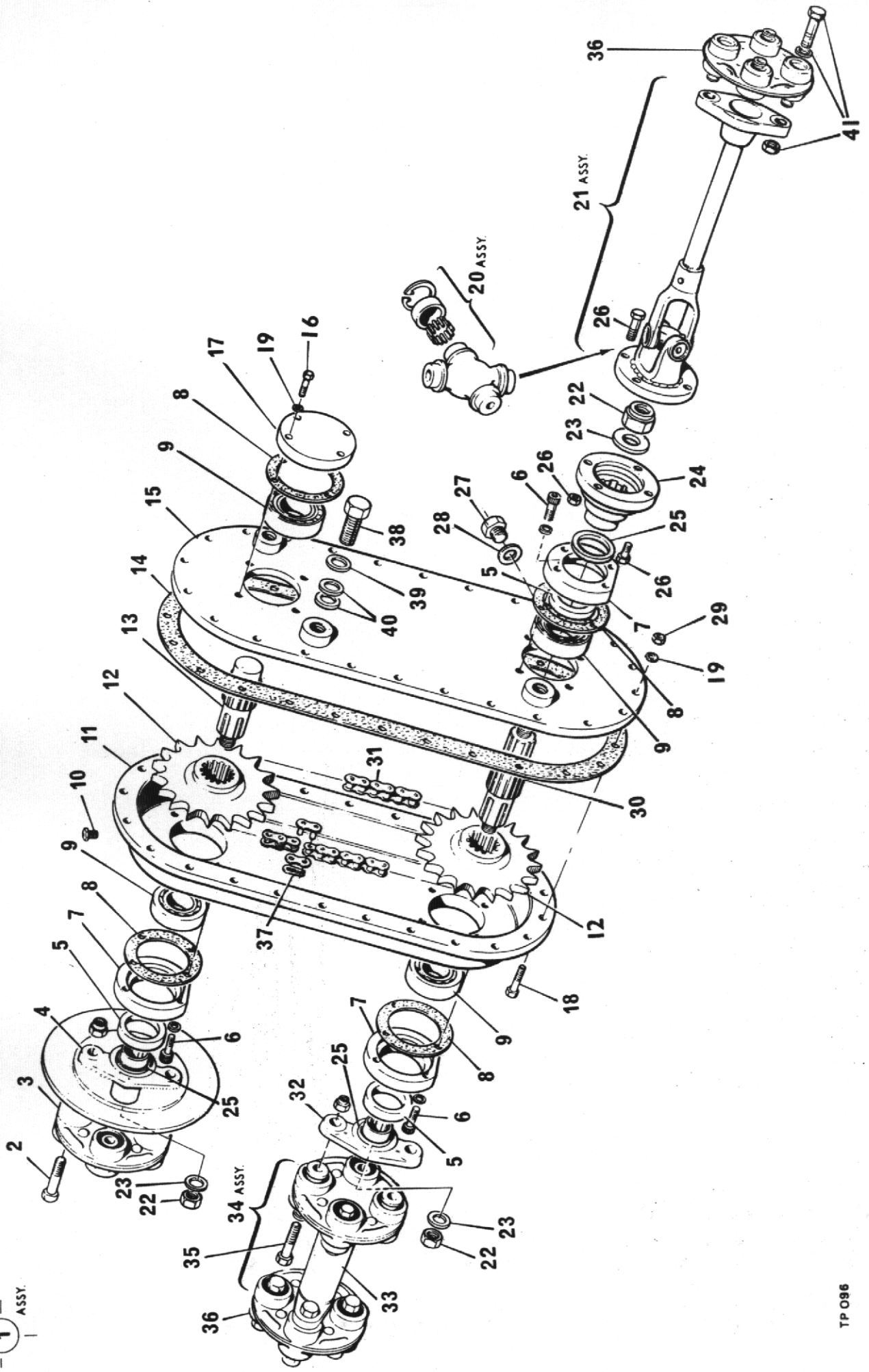

TRANSFER BOX AND PROP SHAFTS

Item No.	Part No.	Description	Qty
1	ASE 142	Transfer Box Complete Including Item 4	1
2	10203A	Coupling Bolt, Washer and Nut	4
3	10203	Coupling C/W Bolts and Nuts	1
4	4-35-400	Brake Disc	1
5	40M 167	Oil Seal	3
6	UFC 416	Cap Screw	12
7	4-35-102	Oil Seal Housing	3
8	CM.2073	Gasket	4
9	CM.2068	Bearing	4
10	CM.2106	Breather	1
11	4-35-96	Main Case	1
12	4-35-17	Chain Wheel 19 Tooth	2
13	4-60-252	Input Shaft	1
14	4-35-20	Joint	1
15	4-35-97	Main Cover	1
16	UBF 51	End Cover Screws	4
17	CM 2528	Cover	1
18	UBF 71	Housing Screw	24
19		Spring Washer 1/4 " dia	28
20	03-501-346	Repair Kit	
21	BSE 134	Prop Shaft	1
22		3/4" UNF Self Locking Nut	2
23		3/4" Dia. Thick Washer	3
24	40M/589	Companion Flange	1
25	CM 2537	Dust Shield	3
26		Prop Shaft Nut and Bolt 1 1/4" x 7/16" BSF	8
27	CP.1002	Drain Plug	1
28	CP.1068	Fibre Washer	1
29	UN.501	Nut	24
30	4-60-253	Output Shaft	1
31	4-35-18	Drive Chain	1
32	40M/580	Companion Flange	1
33	L307	Prop Shaft	1
34	76491	Prop Shaft Assembly Complete	2
35	2407A	Coupling Bolt, Washer and Nut	10
36	2407	Coupling C/W Bolts and Nuts	3
37	4-35-18A	Connecting Link (Chain)	1
38		Setscrew 1/2" BSF x 1 1/4" Long (Drilled for Wire Locking)	3
39		Washer 1/2"	3
40		Spacing Washers	A.R.
41	2408A	Coupling bolt, washer & nut	2

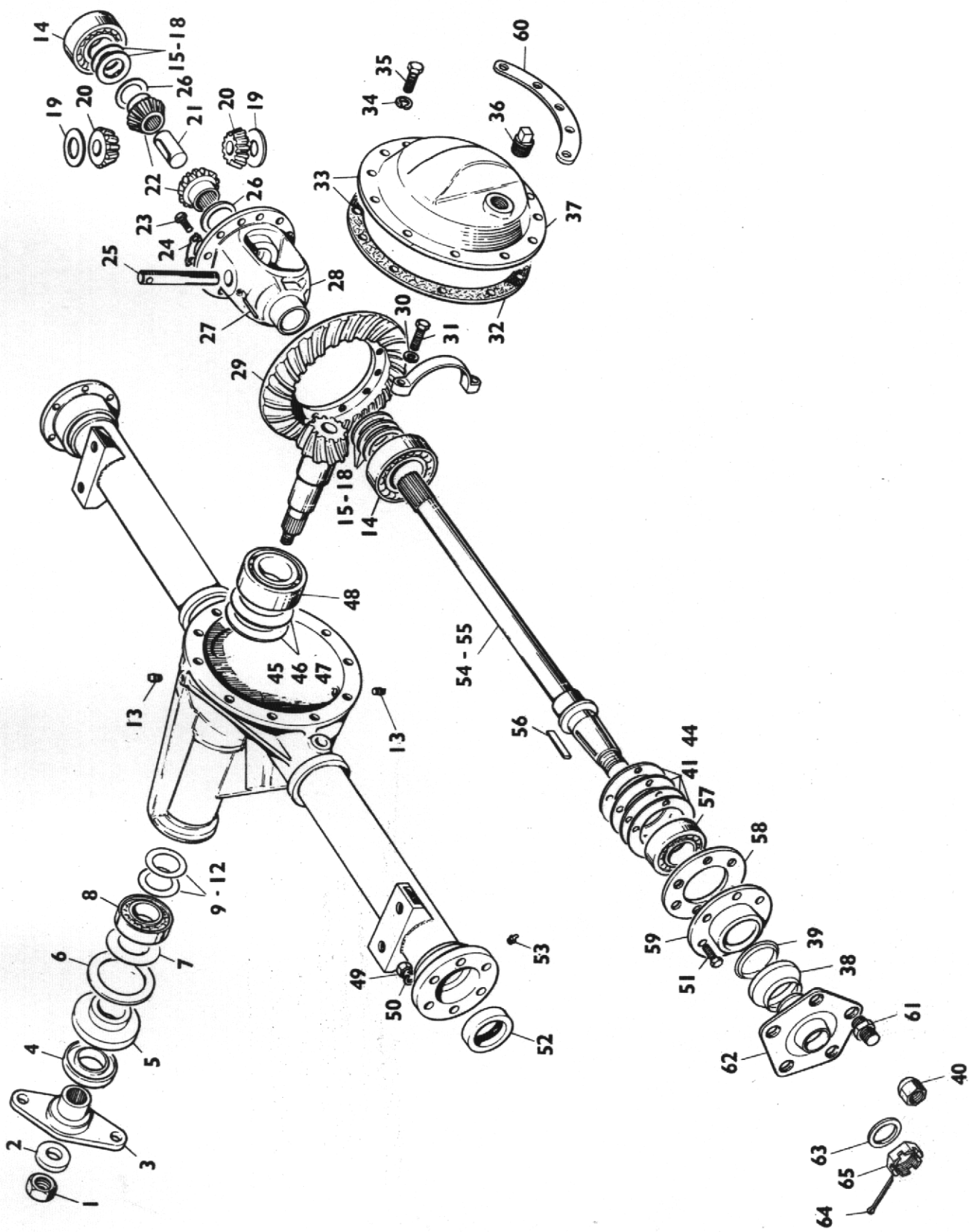

DRIVE AXLE

Item No.	Part No.	Description	Qty.
	5HA-001-274	Drive Axle Complete with drum brakes (2 per m/c)	
1	12 LN-NF9	Pinion Nut	1
2	12W-24	Pinion Nut Washer	1
3	3HA-083-1	Companion Flange Assembly	1
4	2HA-021	Companion Flange Dust Shield	1
5	2HA-019	Pinion Oil Seal	1
6	2HA-020	Pinion Oil Seal Gasket	1
7	2HA-036	Pinion Oil Slinger	1
8	5HA-022	Pinion Bearing, Outer	1
9	5HA-039	Pinion Bearing Adjusting Shim Outer .003"	2
10	5HA-040	Pinion Bearing Adjusting Shim Outer .005"	2
11	5HA-041	Pinion Bearing Adjusting Shim Outer .010"	2
12	5HA-042	Pinion Bearing Adjusting Shim Outer .030"	1
13	HA-059	Filler and Drain Plug (each)	1
14	5HA-024/1	Differential Bearing	2
15	5HA-046	Differential Bearing Shim .003"	2
16	5HA-047	Differential Bearing Shim .005"	2
17	5HA-048	Differential Bearing Shim .010"	2
18	5HA-049	Differential Bearing Shim .030"	1
19	5HA-037	Differential Pinion Mate Thrustwasher	2
20	5HA-008-1	Differential Pinion Mate	2
21	5HA-033-3	Axle Shaft Spacer	1
22	5HA-007-2	Differential Side Gear	2
23	5HA-075-2	Drive Gear Screw	12
24	5HA-074-1	Drive Gear Tabwasher	6
25	5HA-012	Differential Pinion Mate Shaft	1
26	5HA-038	Differential Side Gear Thrustwasher	2
27	5HA-013	Differential Pinion Mate Shaft Lock Pin	1
28	5HA-006	Differential Case	1
29	5HA-105 15	Drive Gear and Pinion Assembly Complete	1
30	8 LW-115	Differential Bearing Cap Washer - Spring	4
31	8 B-NC 36	Differential Bearing Cap Bolt	4
32	5HA-026	Gear Carrier Cover Gasket	1
33	5HA-064-1	Gear Carrier Cover Assembly	1
34	6LW-105	Cover Screw Washer - Spring	10
35	6B-NC10	Cover Screw	10
36	HA-059	Level Plug	1
37	5HA-010	Gear Carrier Cover	1
38	5HA-030-4	Shroud	2
39	5HA-032-14	Seal	2
40	C 177	Wheel Nut	10
41	5HA-050-3	Axle Shaft Bearing Shim .003"	2
42	5HA-051-3	Axle Shaft Bearing Shim .005"	2
43	5HA-052-3	Axle Shaft Bearing Shim .010"	2
44	5HA-053-3	Axle Shaft Bearing Shim .030"	2
45	5HA-043	Pinion Adjusting Shim, Inner .003"	2
46	5HA-044	Pinion Adjusting Shim, Inner .005"	2
47	5HA-045	Pinion Adjusting Shim, Inner .010"	2
48	5HA-023	Pinion Bearing Inner	1
49	6N-NF5	Bearing Retainer Nut	12
50	6W-12	Washer - Spring	2
51	6B-NF 18/B	Bearing retainer bolt	12
52	5HA-027	Axle Shaft Oil Seal	2
53	5HA-056	Axle Shaft Bearing Grease Nipple	2
54	5HA-005-51	Axle Shaft RH	1
55	5HA-005-51	Axle Shaft LH	1

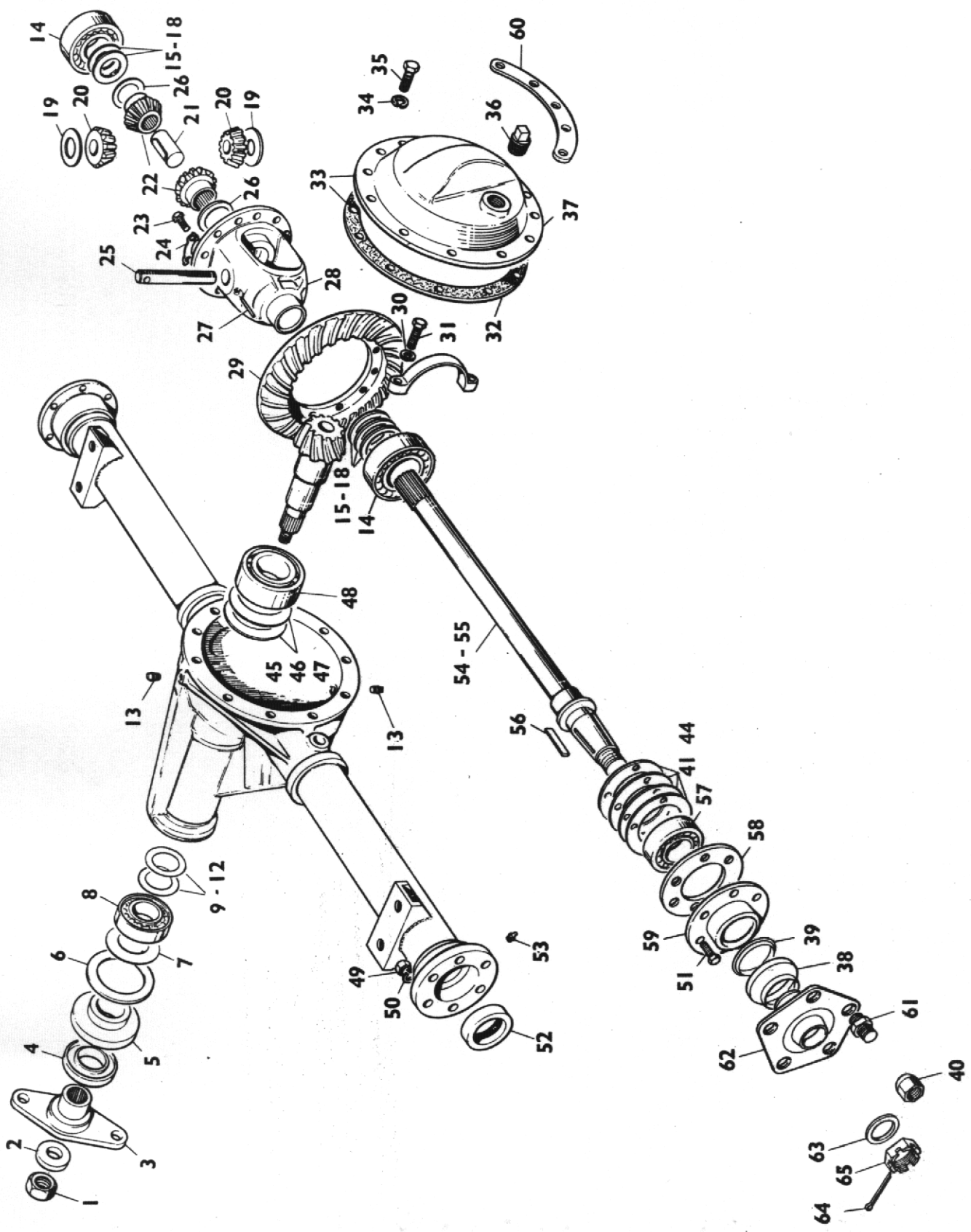

DRIVE AXLE (Continued)

Item No.	Part No.	Description	Qty.
56	5HA-029	Axle Shaft Key	2
57	5HA-025	Axle Shaft Bearing	2
58	5HA-035-5	Axle shaft bearing retainer	2
59	5HA-057-1	Hub oil seal assembly	2
60	4-35-235	Differential cover support	1
61	5HA-055-6	Wheel stud	10
62	5HA-028-37	Wheel hub complete	2
63	18W-32	Axle shaft washer	2
64	12SP-18	Axle shaft cotter	2
65	18-SN-NF-12	Axle shaft Nut	2

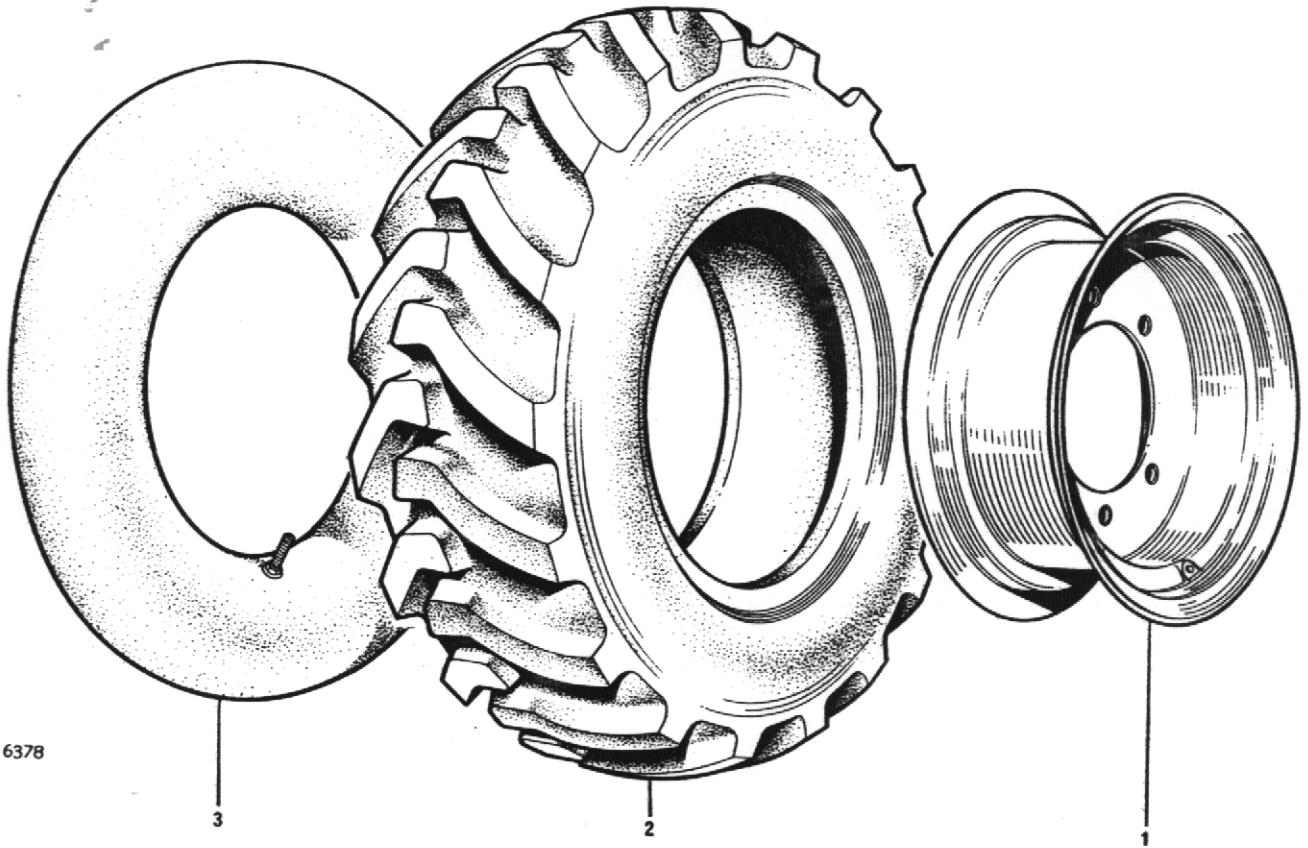

WHEELS AND TYRES

Item No.	Part No.	Description	Qty.
1	24S04	R/H Wheel Assembly	2
	24S03	L/H Wheel Assembly	2
1	30192A01	Wheel rim 5.50 x 16	4
2	20S08	Tyre 7.50 x 16-6 ply	4
3	23S03	Tube 7.50 x 16	4

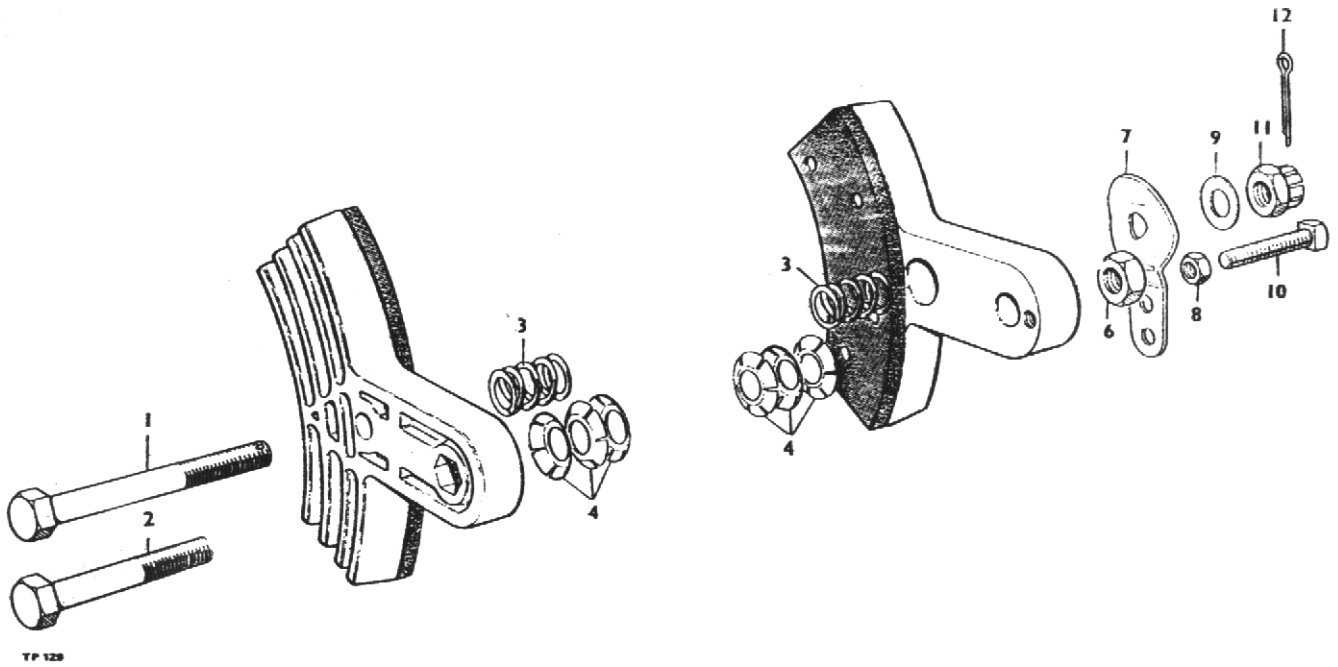

CALIPER, parking brake

Item	Part no	Description	Qty
1A	10578A01	CALIPER, one pair, assembly	1
1	28S02T	SCREW	1
2	28S02P	SCREW	1
3	10578A0101	SPRING, centring	2
4	10578A0102	WASHER, tension	6
6	9S02	NUT	1
7	10578A0104	CAM	1
8	230S01	NUT, locking	1
9	10578A0105	WASHER	1
10	66S01H	SCREW, set	1
11	227S02	NUT, castle	1
12	44S01C	PIN, cotter	1
13	1072A4	PAD c/w rivets	2

DRUM BRAKE ASSEMBLY

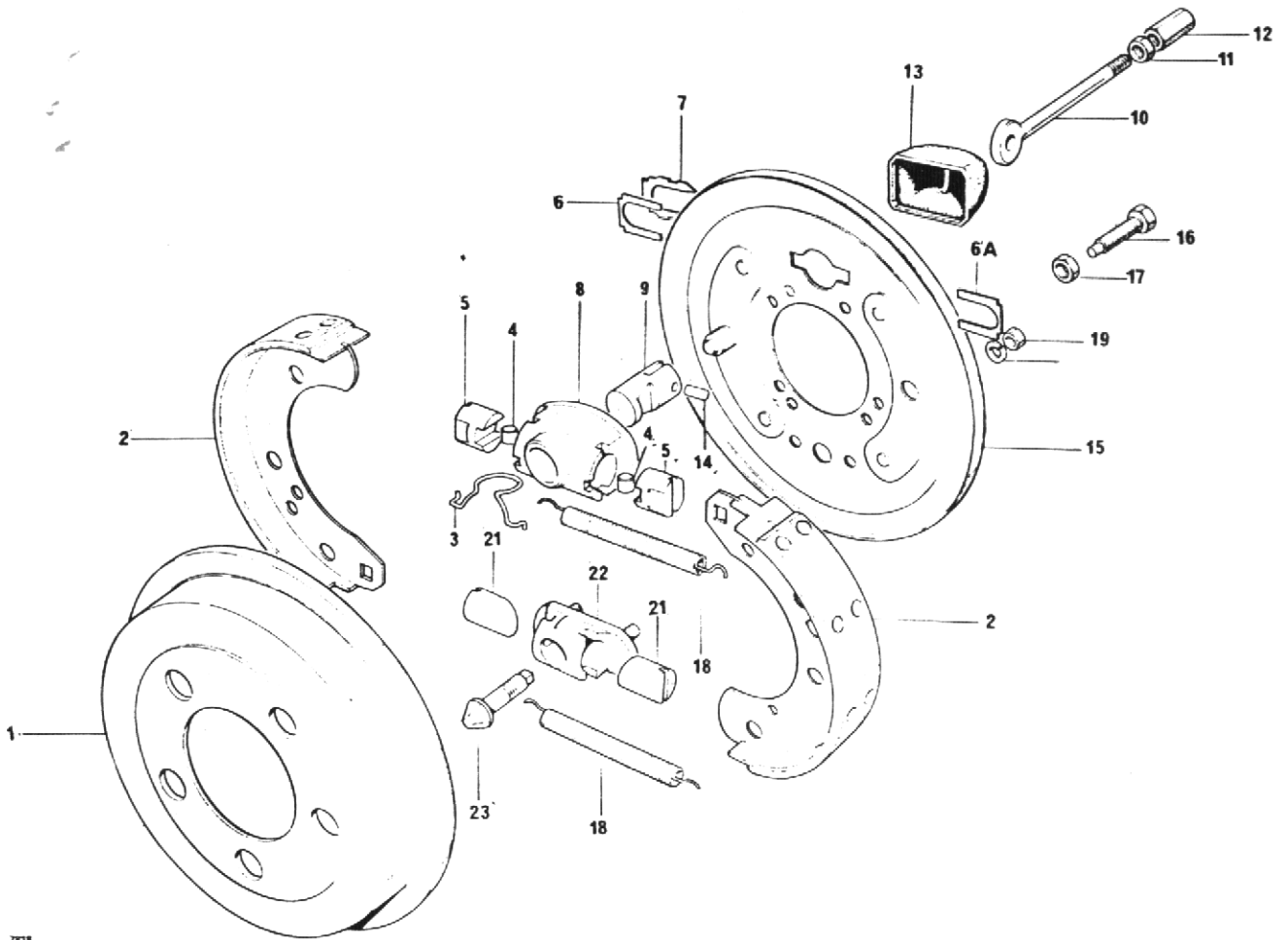

Item	Part No.	Description	Qty.
1	30088.A0128	Brake Drum	1
2	20298.A0101	Lined Shoe	2
3	20298.A0102	Spring	1
4	20298.A0103	Roller	2
5	20298.A0104	Tappet Expander	2
6	20298.A0105	Plate	1
6A	20298.A0106	Plate	1
7	20298.A0107	Locking Plate	1
8	20298.A0108	Expander Housing	1
9	20298.A0109	Plunger	1
10	20298.A0110	Drawlink	1
11	20298.A0111	Locknut	1
12	20298.A0112	Barrel Nut	1
13	20298.A0113	Dust Cover	1
14	20298.A0114	Pin	1
15	20298.A0115	Brake Back Plate	1
16	1S.02C	Setscrew 5/16" BSF	2
17	1S.03	Nut 5/16" BSF	2
18	20298.A0116	Spring	2
19	20298.A0117	Nut	2
20	20298.A0118	Washer	2
21	20298.A0119	Tappet Adjuster	2
22	20298.A0120	Adjuster Housing	1
23	20298.A0121	Wedge	2
24	20298.A0122	Service Kit (Adjuster) (N.I.)	A/R
25	20298.A0123	Adjuster Assy. (Compr: 19-25)	A/R
26	20298.A0124	Expr. Assy. (Compr: items 3,4,5,8,9,10,11,12,& 14)	A/R

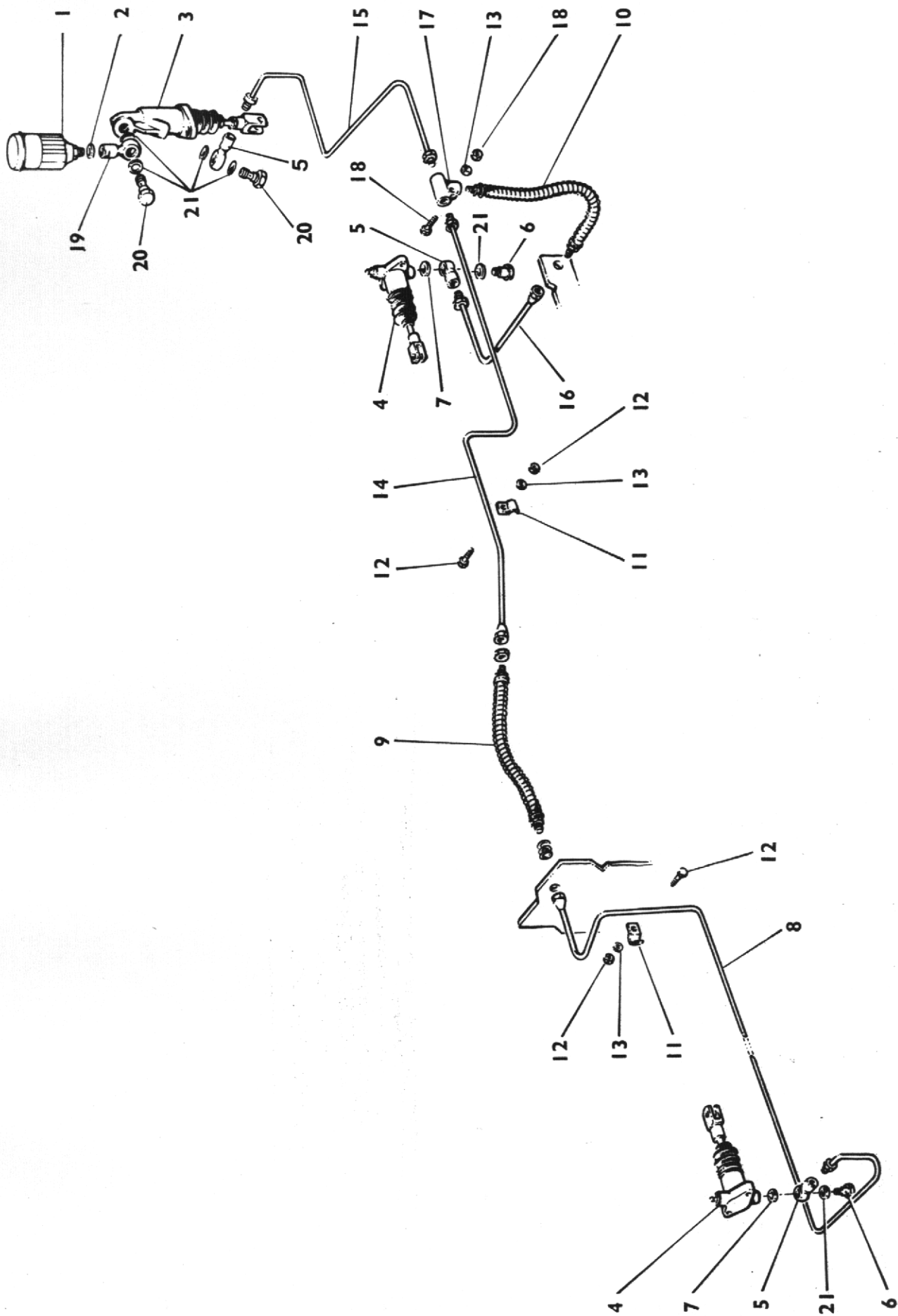

FWD.



BRAKE PIPES & CONNECTIONS

Item No.	Part No.	Description	Qty.
1	64046158	Header Tank	1
2	4-35-378	Copper Washer 3/4" OD. x 7/16" ID. x 1/8" thick.	1
3	64066004	Master Cylinder (See Page 40)	1
4	ASE 149	Slave Cylinder (See Page 41)	2
5	64474287	Banjo	3
6	376102 W	Banjo Bolt	2
7	378703	Washer	2
8	DM 79-5	Pipe	1
9	64047903	Flex Pipe 11"	1
10	64046115	Flex Pipe 9"	1
11	4S 133	P Clip	3
12		Bolt 1/4" BSF x 1" Long & Nut	3
13		Shakeproof Washer 1/4"	4
14	DM 79-4	Brake Pipe	1
15	DM 78-9	Brake Pipe	1
16	DM 79-6	Brake Pipe	1
17	64474341	Tee Piece	1
18		Bolt 1/4" BSF x 1 1/2" Long & Nut	1
19	64474291	Banjo	1
20	64473063	Banjo bolt	2
21	378700	Washer	4

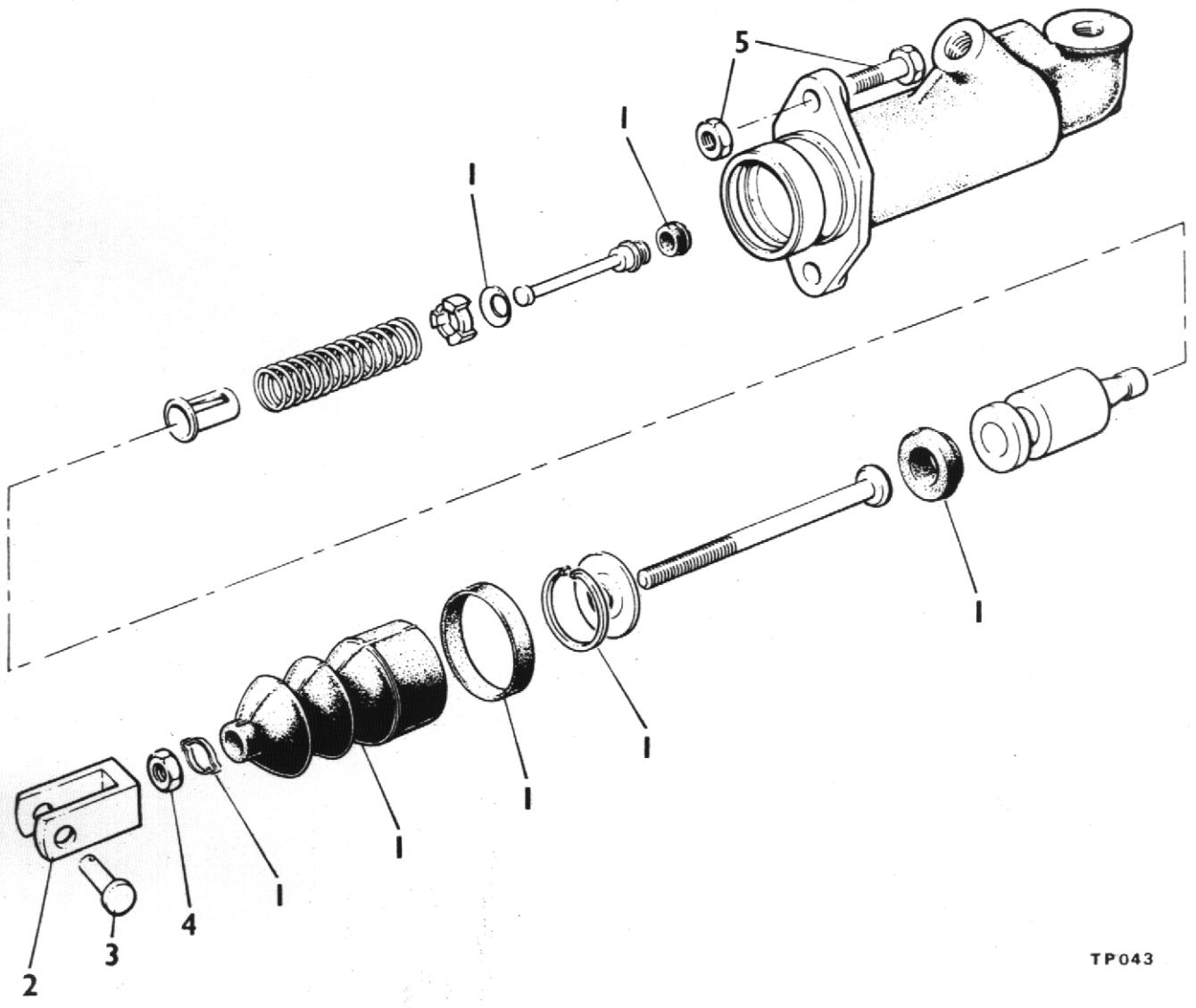

TP043

BRAKE MASTER CYLINDER

Item No.	Part No.	Description	Qty.
	64066004	Master Cylinder Complete	1
1	SP.2636	Service Kit	A/R
2	64671286	Clevis	1
3	C174Y	Clevis Pin	1
4	64100052	Locknut	1
5		Bolt 3/8" BSF x 1 1/2" Long & Nut	2

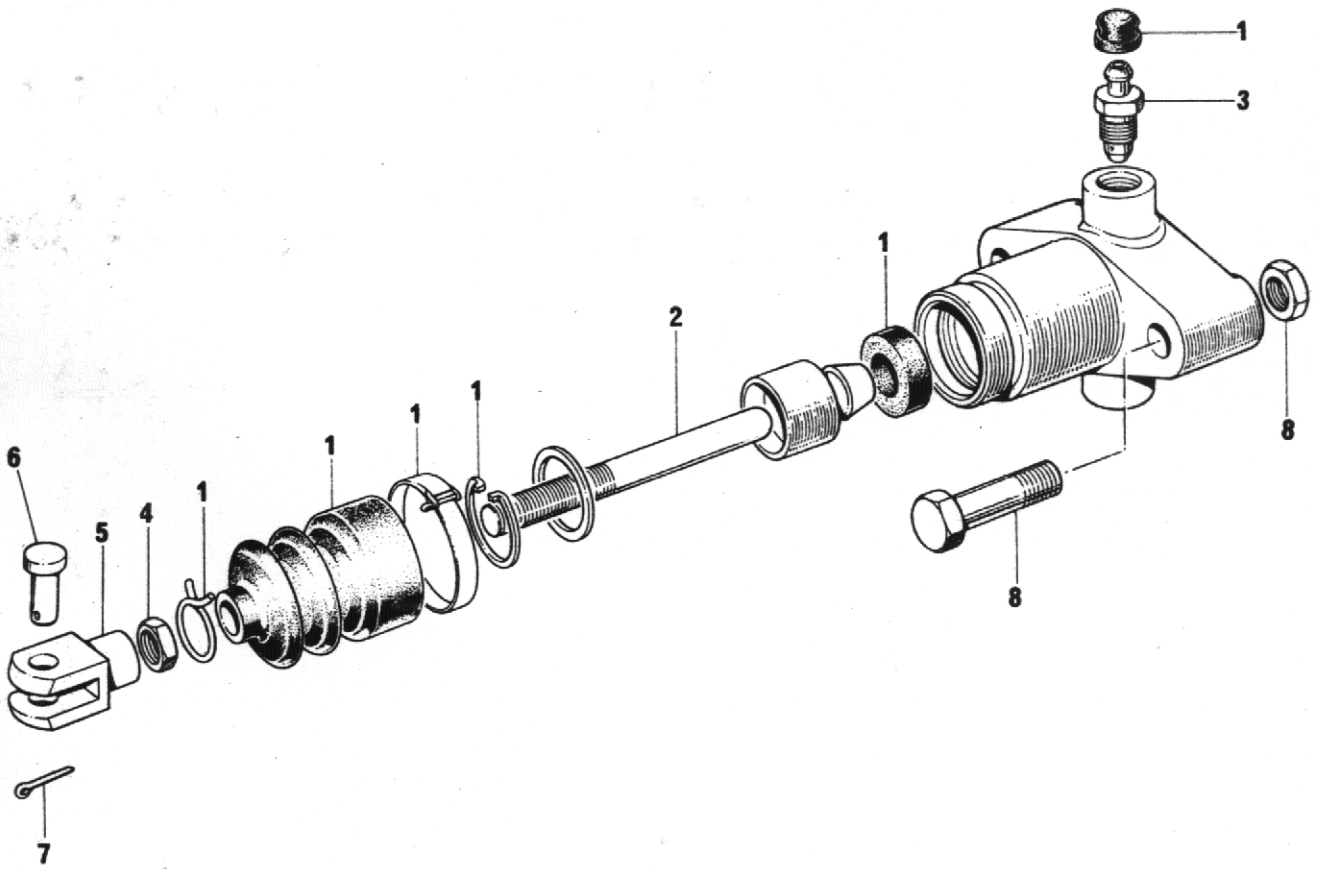

10043

BRAKE SLAVE CYLINDER ASSEMBLY

Item No.	Part No.	Description	Qty.
	ASE 149	Slave Cylinder Complete	1
1	SP 2694	Repair Kit	1
2	ASE 117	Push Rod	1
3	64470444	Bleed Nipple	1
4		Nut 3/8" BSF	1
5	C 174A	Clevis	1
6	C 174X	Clevis Pin	1
7		Split Pin 3/32" Dia.	1
8		Bolt 5/16" BSF x 1 3/4" Long and Nut	2

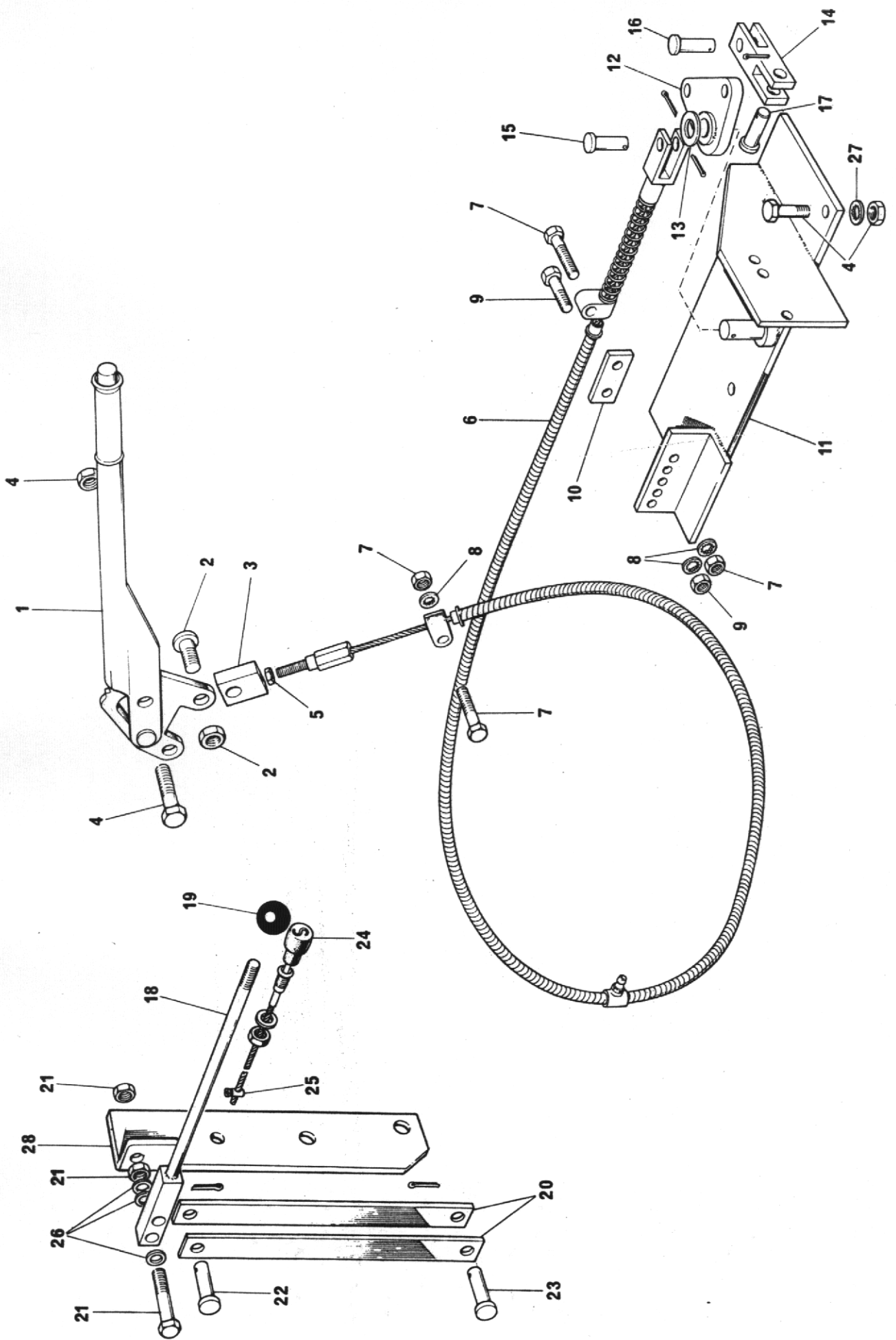

HANDBRAKE, VALVE CONTROL LEVER & ENGINE STOP CONTROL

Item No.	Part No.	Description	Qty
1	303	Handbrake Lever	1
2		Mushroom Head Bolt 3/8" BSF x 1" Long & Nut	2
3	L309	Block	1
4		Bolt 3/8" BSF x 1 1/2" Long & Nut	4
5		Nut 3/8" BSF	1
6	4-35-111	Handbrake Cable	1
7		Bolt 5/16" BSF x 1 3/4" Long & Nut	2
8		Shakeproof Washer 5/16" DIA	3
9		Bolt 5/16" BSF x 1" Long & Nut	1
10	4-35-349	Disc Brake Adjusting Plate	1
11	4-35-350	Transmission Brake Mounting Bracket	1
12	4-35-256	Bell Crank	1
13		Flat Washer 1/2" Dia	1
14	4-35-253	Double Clevis	1
15	C-174X	Clevis Pin	1
16	C-174Y	Clevis Pin	1
17	4-35-264	Clevis Pin	1
18	4-35-276	Control Valve Lever	1
19	2ST88	Knob	1
20	4-35-277	Connecting Link	2
21		Bolt 3/8" BSF x 1 3/4" Long & 2 Nuts	1
22	C-174XL	Pin	1
23	2ST89	Pin	1
24	4-35-82	Engine Stop Control Cable Assy.	1
25	4-35-196	Solderless Nipple	1
26		Flat Washer 3/8" Dia	3
27		Shakeproof Washer 3/8" Dia	3
28	BSE 102	Valve Control Bracket (Petter)	1
	BSE 122	Valve control bracket (Lister)	1

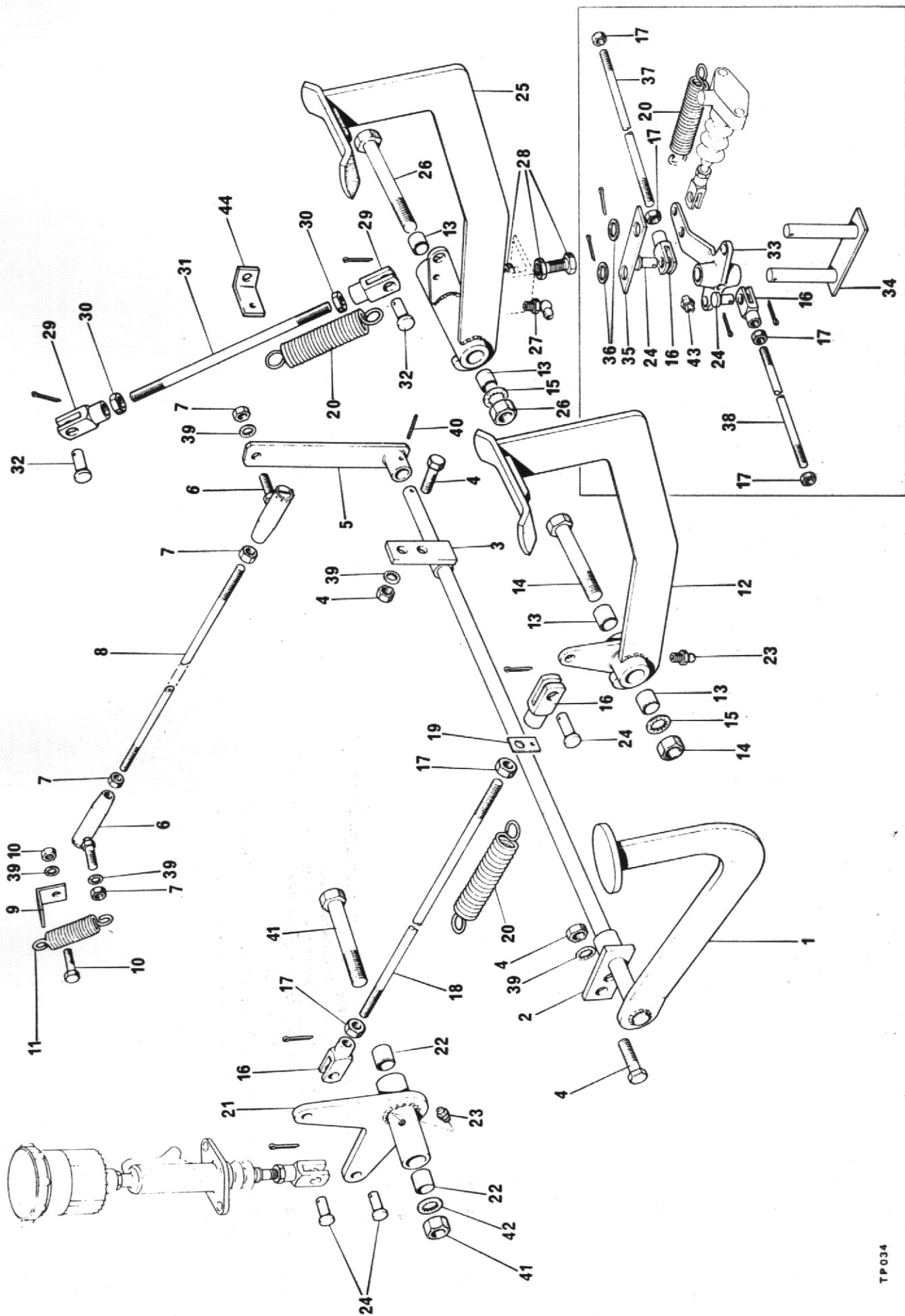

PEDALS AND CONTROLS

Item No.	Part No.	Description	Qty.
1	4-35-322	Accelerator Pedal & Shaft	1
2	4-35-151	Accelerator Mounting Bracket	1
3	ASE 125	Accelerator Mounting Bracket	1
4		Bolt 1/4" BSF x 1" Long & Nut	4
5	F 522	Accelerator Lever	1
6	C160B	Accelerator Rod Ball Eng	2
7		Nut 1/4" BSF	4
8	BSE 107	Accelerator Rod 1/4" BSF x 21 1/4" long (Petter)	1
	BSE 123	Accelerator Rod 1/4" BSF x 30 1/4" long (Lister)	1
9	C163	Spring Attachment Bracket	1
10		Bolt 1/4" BSF x 5/8" Long & Nut	1
11	C173D	Spring	1
12	4-35-125	Brake Pedal	1
13	WB 1010	Bush	4
14		Bolt 5/8" BSF x 3 1/2" Long & Nut	1
15		Shakeproof Washer 5/8"	2
16	C174C	Clevis	6
17		Nut 1/4" UNF	10
18	2ST 107	Footbrake Rod 1/4" UNF x 27" Long	1
19	CT-160-1	Spring Attachment Bracket	1
20	C173B	Spring	4
21	ASE 118	Bell Crank Lever	1
22	WB0808	Bush	2
23	T/ST	Grease Nipple	2
24	C174Y	Clevis Pin	7
25	4-35-367	Clutch Pedal	1
26		Bolt 5/8" BSF x 8 1/2" Long	1
27	T90	Grease Nipple	1
28		Clutch Stop Bolt 3/8" BSF x 1 1/2" Long & 2 Nuts	1
29	C174A	Clevis	2
30		Nut 3/8" BSF	2
31	T21C	Clutch Rod 3/8" BSF x 9" Long	1
32	C174X	Clevis Pin	2
33	C272	Compensator Arm	2
34	C271	Link Assembly	2
35	C189A	Link	2
36		Washer 1/2" Dia	4
37	T20B	Brake Rod 1/4" UNF x 12" Long	2
38	C218-2	Brake Rod 1/4" UNF x 28" Long	2
39		Shakeproof Washer 1/4"	7
40	C129A	Tension Pin	1
41		Bolt 1/2" BSF x 4 1/2" Long & Nut	1
42		Shakeproof Washer 1/2"	1
43	5ST 100	Grease nipple	2
44	BSE 131	Clutch Return spring bracket	1

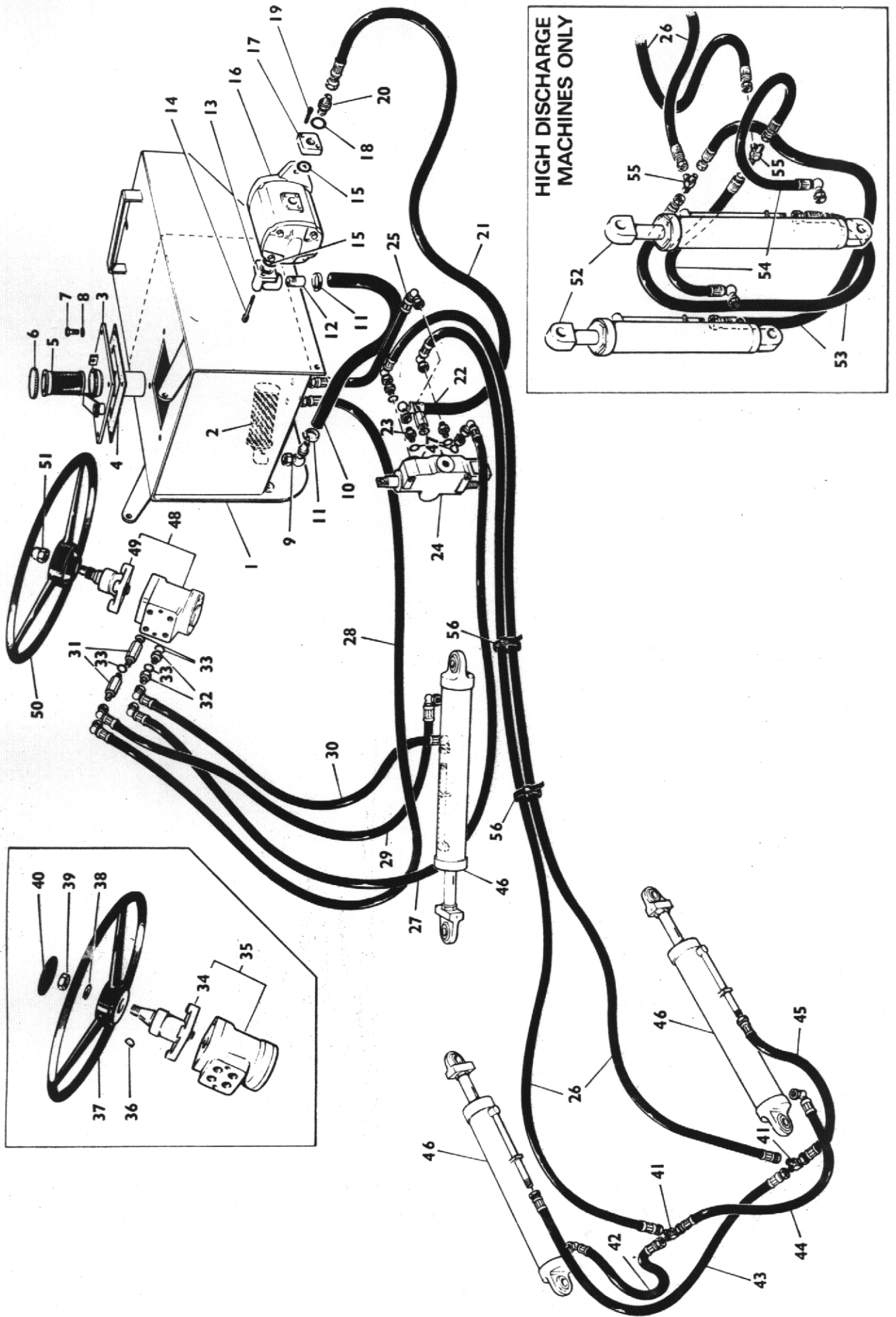

HYDRAULIC PIPES & FITTINGS

Item No.	Part No.	Description	Qty.
1	BSE 108	Hydraulic Tank (See Page 18, 19)	1
2	UC 1457	Suction Filter	1
3	4-35-187	Cover Plate Assembly	1
4	T 18 B	Gasket	1
5	P 1145	Strainer	1
6	P 2578-2	Cap	1
7		Bolt 5/16" UNF x 3/4" Long & Nut	4
8		Shakeproof Washer 5/16"	4
9	BSE 109	90° Hose Fitting 3/4" BSP	1
10	4-35-312	Hose 3/4" cotton braid x 36" long (Petter)	1
	BSE 126	Hose 3/4" cotton braid x 34" long (Lister)	1
11	T 63 M	Hose Clip	2
12	T 48	Pump Inlet Adaptor	1
13	IPE 4	Pump Elbow	1-Petter 2-Lister
14		Cap Screw 5/16" UNF x 2 1/4" Long	2-Petter 4-Lister
15	DH 69 A5	'O' Ring	2
16	IP3072-CPSFB	Pump (Petter) see page 48	1
	IP3044-ATDFB	Pump (Lister)	1
17	4-35-261	Adaptor (Petter only)	1
18	T141	Seal 3/8" BSP (Petter)	1
	T14H	Seal 1/2" BSP (Lister)	1
19		Cap Screw 5/16" UNF x 1" Long (Petter Only)	2
20	T14J	Adaptor 3/8" BSP x 3/8" BSP (Petter)	1
	T63K	Adaptor 1/2" BSP x 3/8" BSP (Lister)	1
21	4-60-133	Hose 3/8" x 48" ST-90 (Petter)	1
	4-35-108H	Hose 3/8" x 33 1/2" ST-90 (Lister)	1
22	4-60-158	Adaptor 3/8" BSP x 7/8" JIC (Long)	1
23	4-60-159	Adaptor 3/8" BSP x 7/8" JIC (Std)	4
24	300-024-GAA	Control Valve (See Pages 50, 51)	1
25	2ST 72 C	Hose 3/8" x 13 1/4" ST-90	1
26	4SH 54	Hose 3/8" x 99" ST-90	2
27	4-35-293	Hose 3/8" x 60" 90-90 (Petter)	1
	4-35-246	Hose 3/8" x 67" ST-90 (Lister)	1
28	4-60-137	Hose 3/8" x 61" ST-90	1
29	4-35-245	Hose 3/8" x 43" 90-90	1
30	4-35-244	Hose 3/8" x 36" 90-90	1
31	4-60-115	Adaptor 3/8" BSP x 3/4 UNF (Long)	2
32	4-35-40K	Adaptor 3/8" BSP x 3/4 UNF	2
33	2ST 72J	'O' Ring 3/4"	4
34	SCA 315	Steering Valve Column (Taper/Key type)	1
35	UE 160	Steering Valve Complete (Taper/Key type)	1
36		Woodruff Key No. 11	1
37	153	Steering Wheel (Taper/Key type)	1
38		Washer 3/4"	1
39	4-60-247	Steering Wheel Nut 3/4" UNF	1
40	153 A	Steering Wheel Cap	1
41	2ST 72M	Tee Piece	2
42	4-35-365	Hose 3/8" x 20" ST-90	1
43	3SHD 65	Hose 3/8" x 31 1/2" ST-ST	1
44	2ST 72 D	Hose 3/8" x 34 1/4 ST-90	1
45	4-35-40E	Hose 3/8" x 25" ST-ST	1
46	TD 3894	Hydraulic Ram (See Page 49)	3
47	S 9698	'O' Ring 7/8"	5
48	OSP 160 SMMT	Steering Valve Complete (taper/spline type)	1
49	D-15-2099	Steering Valve column (taper/spline type)	1
50	347K	Steering wheel (taper/spline type)	1
51	C304	Steering wheel domed nut 5/8" UNF	1
52	BE3	Hydraulic Ram (See Page 52)	2
53	4-35-108J	Hose 3/8" x 36" ST-ST	2
54	4-35-365	Hose 3/8" x 20" ST-90	2
55	2ST72M	Tee piece	2
56		Hose clip (45-61 mm)	2
	2ST 72N	Elbow 3/8" BSP (Control Valve to Steering Supply and Tank Return) Lister only	2

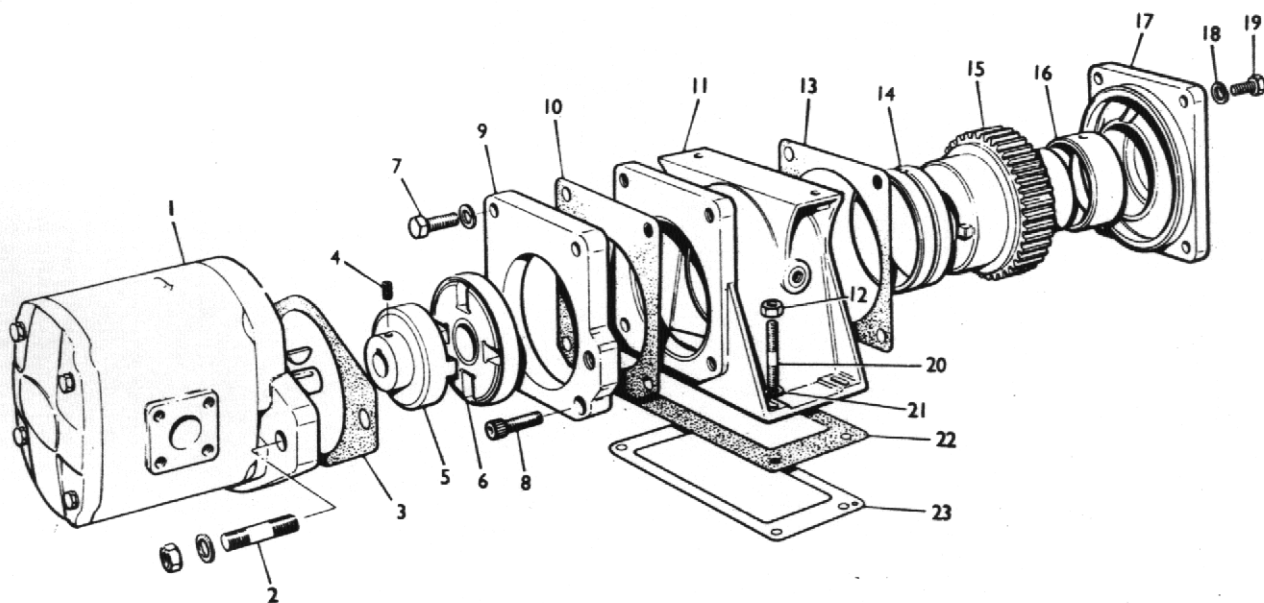

HYDRAULIC PUMP & DRIVE (PETTER ONLY)

Item No.	Part No.	Description	Qty.
1	IP3072CPSFB	Pump complete	1
2		Stud, washer & nut	2
3	334932	Joint	1
4	724202	Socket Screw 1/4" BSF x 5/16" Long	1
5	334931	Coupling (Pump Half)	1
6	266185	Coupling Assy	1
7	725049	Bolt 3/8" BSF x 1" Long	2
8	724056	Cap Screw 3/8" BSF x 3/4" Long	2
9	292709	Spigot Plate	1
10	266159	Joint	1
11	2-197597	Pump Housing	1
12	726003	Nut 3/8" BSF	4
13	264702	Joint	1
14	2-264704	Bearing	1
15	334968	Gearwheel	1
16	2-202485	Bearing	1
17	264701	Cover - Pump Housing	1
18	786029	Spring Washer - 5/16"	4
19	722024	Bolt 5/16" BSF x 5/8" Long	4
20	760061	Stud 3/8" BSF x 1 3/8" Long	4
21	786030	Spring Washer - 3/8"	4
22	264700	Joint	1
23	264706	Shim	A.R.

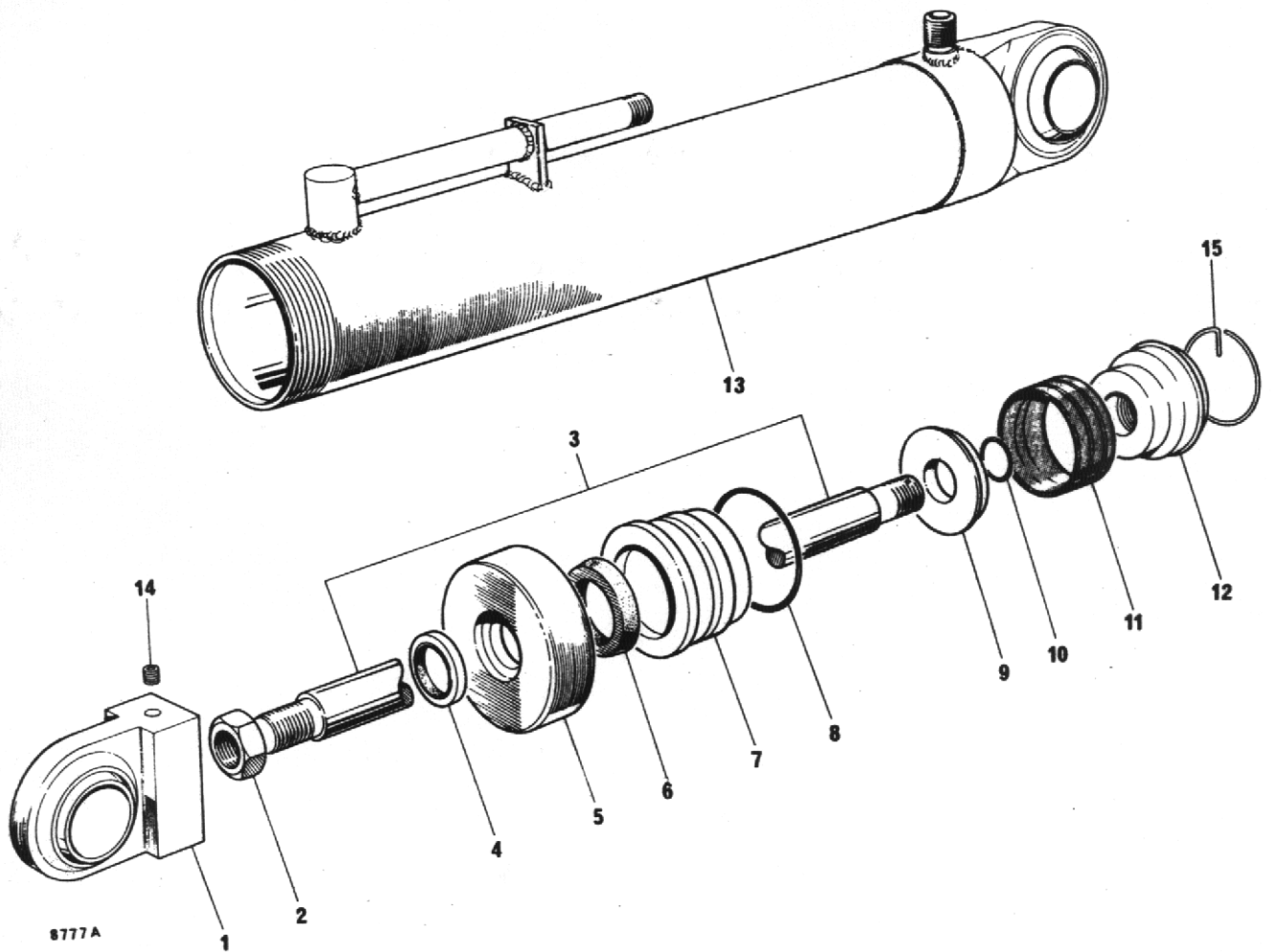

HYDRAULIC RAM

Item No.	Part No.	Description	Qty.
	TD3894	Ram Complete (3 Per Machine — 1 on high discharge machine)	
1	K1/11	Piston Rod Fitting	1
2	K1/19	Locknut	1
3	K1/2	Piston Rod	1
4	K1/18	Wiper	1
5	K1/4	Tube Cap	1
6	K1/17	Sleeve Seal	1
7	K1/5	Sleeve	1
8	K1/16	Sleeve 'O' Ring	1
9	K1/15	Backing Washer	1
10	K1/13	Piston 'O' Ring	1
11	K1/12	Piston Seal	1
12	K1/14	Piston Head	1
13	K1/20	Cylinder, Bosses & End Cap	1
14	K1/21	Grub Screw	1
15	K1/22	Spring Ring	1

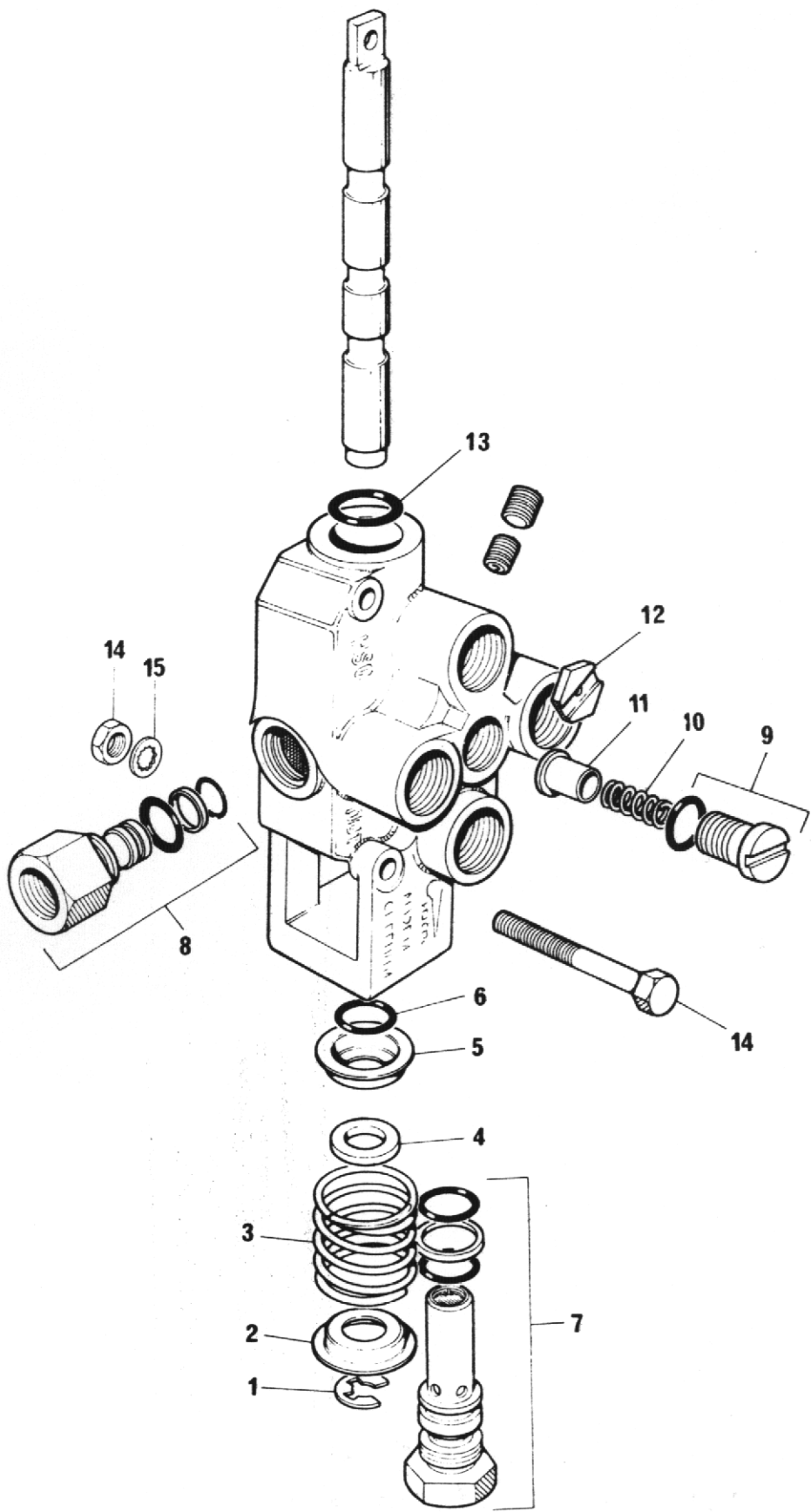

HYDRAULIC CONTROL VALVE

Item No.	Part No.	Description	Qty.
	300-024-GAA	Control Valve Assembly (1 Per M/c)	-
1	16124-50	Clip Ring (1/2" Shaft)	1
2	15546-6	Shallow Washer	1
3	30501-39	Spool Spring	1
4	16048-31	Washer Spacer	1
5	30501-10	Deep Washer	1
6	16003-12	'O' Ring 3/32" x 5/8" I/D	1
7	300-055-J9A	Relief Valve Assembly	1
8	30501-15	Pressure Beyond Plug Assembly	1
9	30501-17	Lift Check Plug Assembly	1
10	30501-13	Lift Check Spring	1
11	30501-12	Lift Check Plunger	1
12	16097-451	Orifice Plate	1
13	16004-63	'O' Ring	1
14		Bolt 5/16" UNF x 2 1/2" long and Nut	2
15		Shakeproof Washer	2

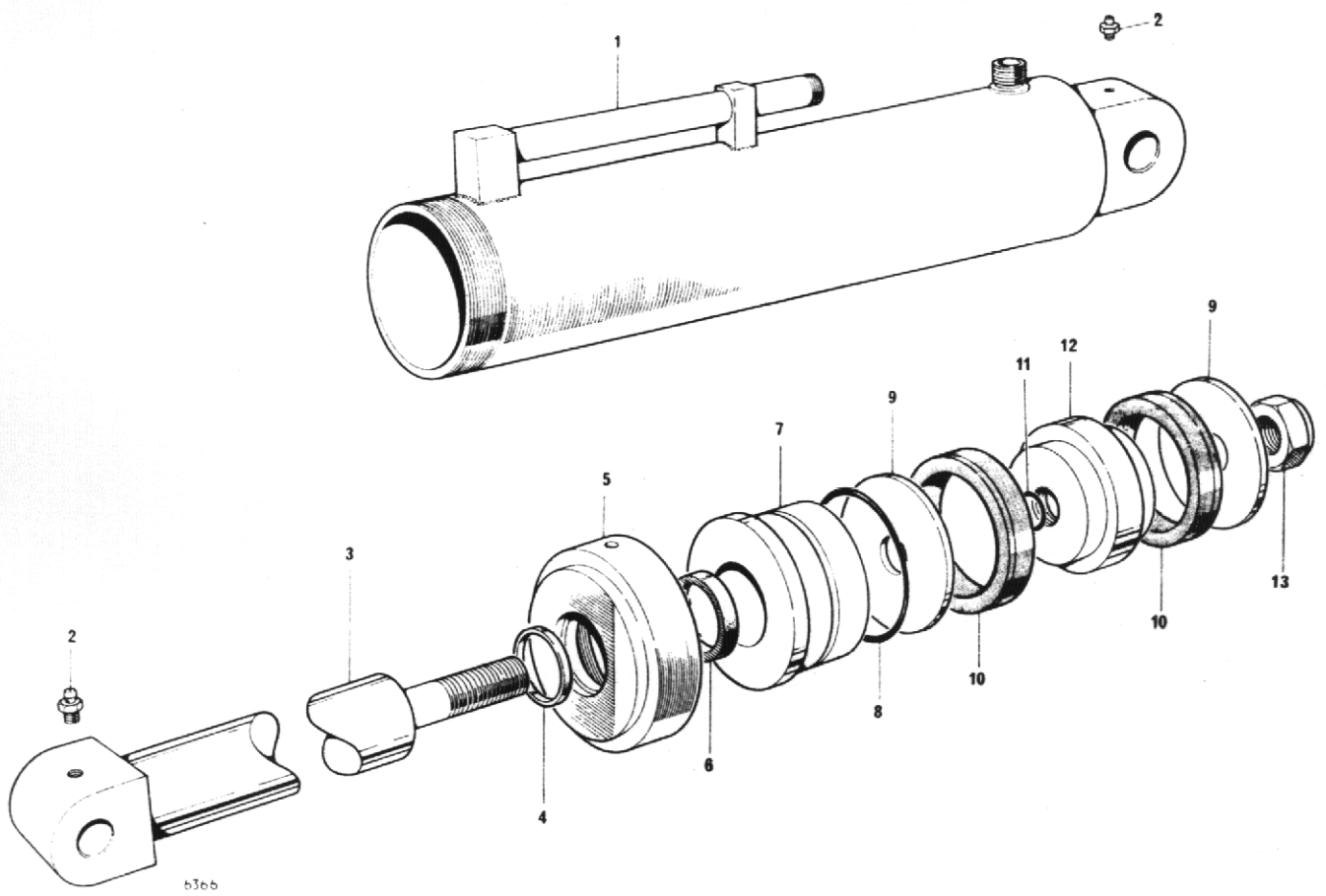

HIGH DISCHARGE HYDRAULIC RAM

Item No.	Part No.	Description	Qty.
	BE-3	Ram Assembly Complete (Two per high discharge m/c's only)	
1	BE3-21	Ram Body	1
2	BE3-20	Grease Nipple	2
3	BE3-22	Piston Rod Assembly	1
4	BE3-15	Wiper	1
5	BE3-6	Tube Cap	1
6	BE3-16	Sleeve Seal	1
7	BE3-7	Sleeve	1
8	BE3-13	Sleeve 'O' Ring	1
9	BE3-10	Backing Washer	2
10	BE3-14	Piston Seal	2
11	BE3-12	Piston 'O' Ring	1
12	BE3-9	Piston Head	1
13	BE3-11	Lock Nut	1

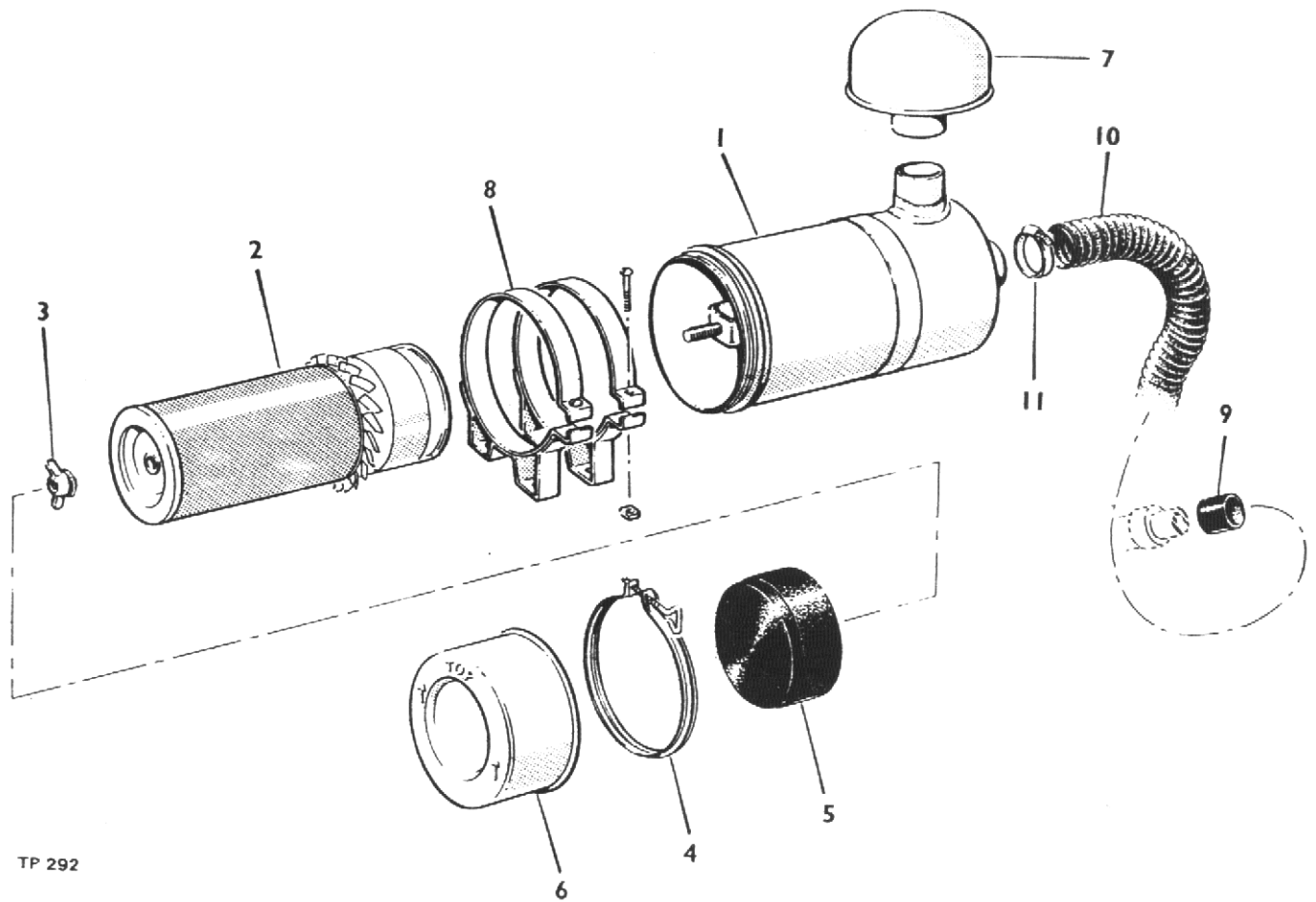

TP 292

AIR CLEANER

Item No.	Part No.	Description	Qty.
1	10532A02	Air Cleaner Assembly	1
2	10532A0101	Element	1
3	V600487	Nut & Gasket Kit	1
4	220229002	Clamp Body	1
5	220229003	Skirt, baffle	1
6	220229004	Cup	1
7	10534A02	Stack Cap	1
8	10533A02	Bracket	2
9	10320A06	Sleeve Adapter	1
10		Hose Flexible 2" Bore x 20" Long (Petter)	1
		Hose Flexible 2" Bore x 27" Long (Lister)	1
11	97S12	Hose Clip	2

DECIMAL, FRACTIONAL AND METRIC EQUIVALENTS

Inches		Milli- metres	Inches		Milli- metres
Fractions	Decimals		Fractions	Decimals	
1/64	0.015625	0.397	33/64	0.515625	13.097
1/32	0.03125	0.794	17/32	0.53125	13.494
3/64	0.046875	1.191	35/64	0.546875	13.891
1/16	0.0625	1.588	9/16	0.5625	14.288
5/64	0.078125	1.984	37/64	0.578125	14.684
3/32	0.09375	2.381	19/32	0.59375	15.081
7/64	0.109375	2.778	39/64	0.609375	15.478
1/8	0.125	3.175	5/8	0.625	15.875
9/64	0.140625	3.572	41/64	0.640625	16.272
5/32	0.15625	3.969	21/32	0.65625	16.669
11/64	0.171875	4.366	43/64	0.671875	17.066
3/16	0.1875	4.763	11/16	0.6875	17.463
13/64	0.203125	5.159	45/64	0.703125	17.859
7/32	0.21875	5.556	23/32	0.71875	18.256
15/64	0.234375	5.953	47/64	0.734375	18.653
1/4	0.250	6.350	3/4	0.750	19.050
17/64	0.265625	6.747	49/64	0.765625	19.447
9/32	0.28125	7.144	25/32	0.78125	19.844
19/64	0.296875	7.541	51/64	0.796875	20.241
5/16	0.3125	7.938	13/16	0.8125	20.638
21/64	0.328125	8.334	53/64	0.828125	21.034
11/32	0.34375	8.731	27/32	0.84375	21.431
23/64	0.359375	9.128	55/64	0.859375	21.828
3/8	0.375	9.525	7/8	0.875	22.225
25/64	0.390625	9.922	57/64	0.890625	22.622
13/32	0.40625	10.319	29/32	0.90625	23.019
27/64	0.421875	10.716	59/64	0.921875	23.416
7/16	0.4375	11.113	15/16	0.9375	23.813
29/64	0.453125	11.509	61/64	0.953125	24.209
15/32	0.46875	11.906	31/32	0.96875	24.606
31/64	0.484375	12.303	63/64	0.984375	25.003
1/2	0.500	12.700	1	1.000	25.400

INCHES INTO MILLIMETRES

Inches	0	1	2	3	4	5	6	7	8	9
0	0	25.40	50.80	76.20	101.60	127.00	152.40	177.80	203.20	228.60
10	254.00	279.40	304.80	330.20	355.60	381.00	406.40	431.80	457.20	482.60
20	508.00	533.40	558.80	584.20	609.60	635.00	660.40	685.80	711.20	736.60
30	762.00	787.40	812.80	838.20	863.60	889.00	914.40	939.80	965.20	990.60
40	1016.00	1041.40	1066.80	1092.20	1117.60	1143.00	1168.40	1193.80	1219.20	1244.60
50	1270.00	1295.40	1320.80	1346.20	1371.60	1397.00	1422.40	1447.80	1473.20	1498.60
60	1524.00	1549.40	1574.80	1600.20	1625.60	1651.00	1676.40	1701.80	1727.20	1752.60
70	1778.00	1803.40	1828.80	1854.20	1879.60	1905.00	1930.40	1955.80	1981.20	2006.60
80	2032.00	2057.40	2082.80	2108.20	2133.60	2159.00	2184.40	2209.80	2235.20	2260.60
90	2286.00	2311.40	2336.80	2362.20	2387.60	2413.00	2438.40	2463.80	2489.20	2514.61

Use in conjunction with above table.

Example: Find equivalent mm. for 84 5/8".

$$84'' = 2133.60 \text{ mm.}$$

$$5/8'' = 15.875 \text{ mm.}$$

$$84 \text{ } 5/8'' = 2149.475 \text{ mm.}$$

CALIFORNIA

Proposition 65 Warning

Diesel engine exhaust and some of its constituents are known to the State of California to cause cancer, birth defects, and other reproductive harm